



SNS COLLEGE OF ENGINEERING

Kurumbapalayam (Po), Coimbatore – 641 107

An Autonomous Institution

Accredited by NBA – AICTE and Accredited by NAAC – UGC with ‘A’ Grade

Approved by AICTE, New Delhi & Affiliated to Anna University, Chennai

**DEPARTMENT OF ELECTRONICS AND COMMUNICATION
ENGINEERING**

Sub: Microcontroller Programming And Interfacing

Subcode:23ECB202

Unit-I

PIC Microcontrollers: History, Features, & Architecture

Topic: PIC16F877A Block Diagram



Introduction

- What is PIC?
 - A family of Harvard architecture microcontrollers made by Microchip Technology
 - Derived from the PIC1650 originally developed by General Instrument Microelectronics Division.
 - The name PIC was originally an acronym for "**Programmable Intelligent Computer**".



Introduction

Why PIC is popular?

- low cost, wide availability with high clock speed
- availability of low cost or free development tools
- Only 37 instructions to remember
- serial programming and re-programming with flash memory capability
- Its code is extremely efficient, allowing the PIC to run with typically less program memory than its larger competitors
- PIC is very small and easy to implement for non-complex problems and usually accompanies to the microprocessors as an interface



Two Different Architectures

- Harvard Architectures
(newer arch.)

- Von-Neumann Architecture

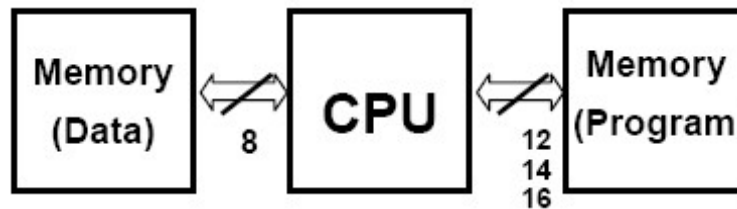

Harvard Architecture

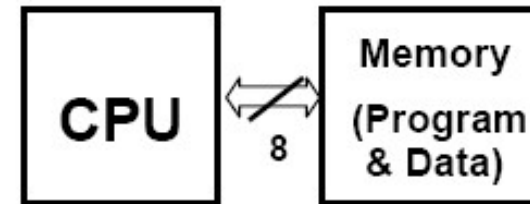

Von-Neumann Architecture

Two Different Architectures

- Harvard Architectures

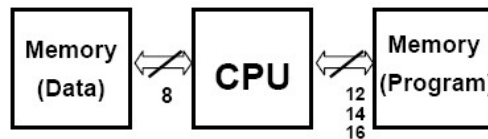

Harvard Architecture

- Used mostly in RISC CPUs
- Separate program bus and data bus: can be of different widths
- For example, PICs use:
 - Data memory (RAM): a small number of 8bit registers
 - Program memory (ROM): 12bit, 14bit or 16bit wide (in EPROM, FLASH, or ROM)

- Von-Neumann Architecture

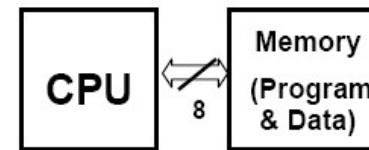

Von-Neumann Architecture

- Used in: 80X86 (CISC PCs)
- Only one bus between CPU and memory
- RAM and program memory share the same bus and the same memory, and so must have the same bit width
- **Bottleneck:** Getting instructions interferes with accessing RAM



ARCHITECTURE

- IC Microcontroller architecture is based on Harvard architecture and supports RISC architecture (Reduced Instruction Set Computer).
- The PIC microcontroller architecture consists of memory organization (RAM, ROM, STACK), CPU, timers, counters, ADC, DAC, serial communication, a CCP (Capture, Compare, PWM) module, and I/O ports.
- PIC microcontroller also supports protocols like CAN, SPI, and UART for interfacing with other peripherals.



PIC MICROCONTROLLER ARCHITECTURE

block diagram

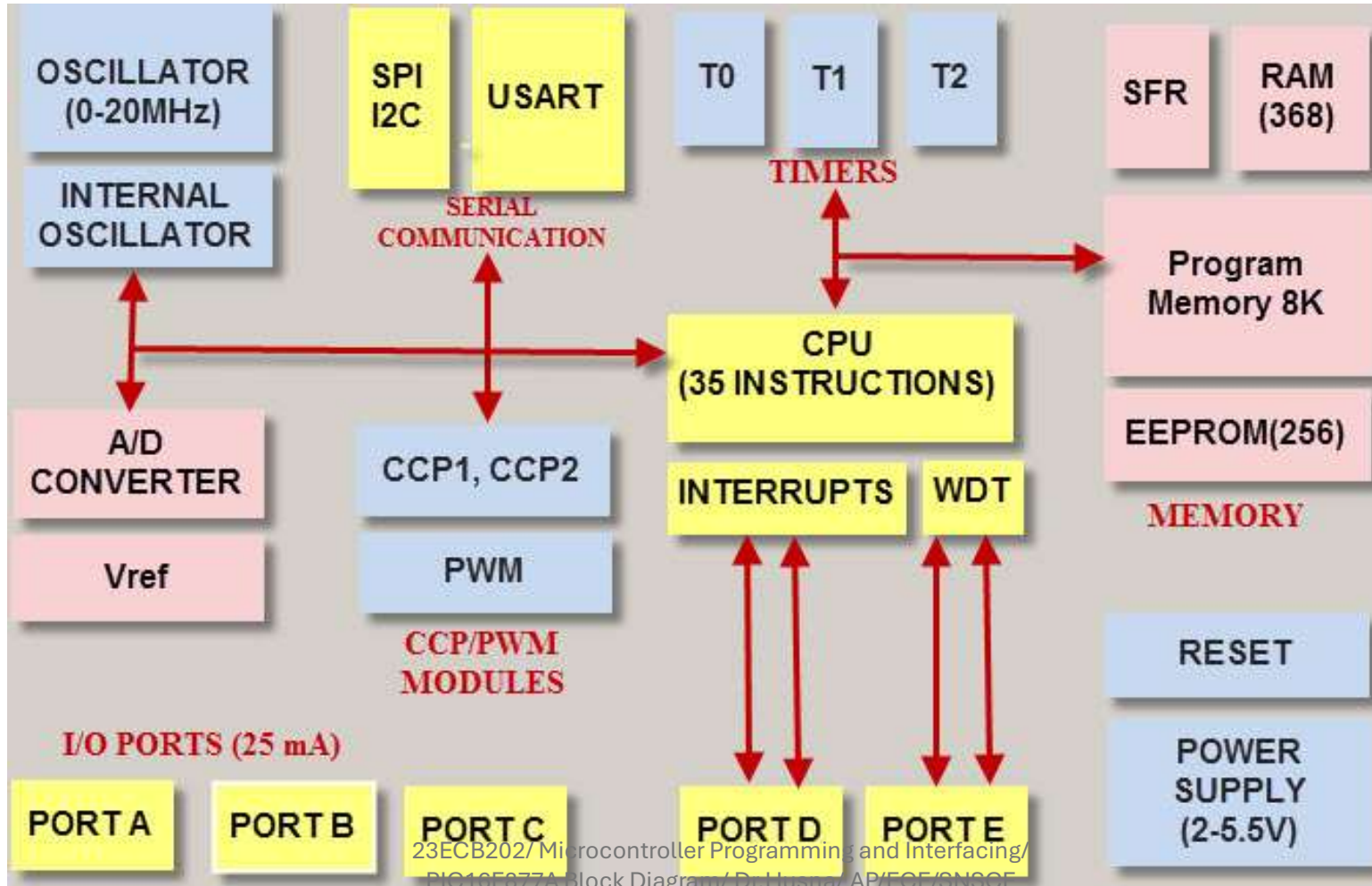



CPU (Central Processing Unit):

PIC microcontroller's CPU consists of

1. Arithmetic logic unit (ALU)
2. Memory unit (MU)
3. Control unit (CU)
4. Accumulator

- ALU is used for arithmetic operations and for logical decisions.
- Memory is used for storing the instructions after processing.
- Control unit is used to control the internal and external peripherals which are connected to the CPU and accumulator is used for storing the results.

MEMORY ORGANIZATION:

- PIC microcontroller memory module consists of mainly 3 types of memories:
 1. Program memory
 2. Data memory



PROGRAM MEMORY:

- It contains the written program after we burned it in microcontroller.
- Program Counter executes commands stored in the program memory, one after the other.
- PIC microcontroller can have 8K words x 14 bits of Flash program memory that can be electrically erased and reprogrammed.
- Whenever we burn program into the micro, we erase an old program and write a new one.



DATA MEMORY:

- It is a RAM type which is used to store the data temporarily in its registers.
- The RAM memory is classified into banks. Each bank extends up to 7Fh (128 bytes).
- Number of banks may vary depending on the microcontroller.
- PIC16F84 has only two banks. Banks contain Special Function Registers (SFR) and General Purpose Registers (GPR).
- The lower locations of each bank are reserved for the Special Function Registers and upper locations are for General Purpose Registers.



General Purpose Registers (GPR):

- These registers don't have any special function.
- These are used for general purpose for multiplying, addition or subtraction and then storing the results in other registers.
- CPU can easily access the data in these registers.

Special Function Registers (SFR):

- These registers are used for special purposes and they cannot be used as normal registers.
- Their function is set at the time of manufacturing.
- They perform the function assigned to them and user cannot change the function of SFR.
- Three important SFRs for programming are:

1. STATUS register : It changes the bank
2. PORT registers : It assigns logic values 0 or 1 to the ports
3. TRIS registers : It is a data direction register for input and



DATA EEPROM:

- This memory allows storing the variables as a result of burning the written program.
- It is readable and writable during normal operation (over the full VDD range).
- This memory is not directly mapped in the register file.
- It is indirectly addressed through the SFRs.
- There are six SFRs which are used to read and write to this memory (EECON1, EECON2, EEDATA, EEDATH, EEADR, EEADRH).



PIC16F877a Architecture

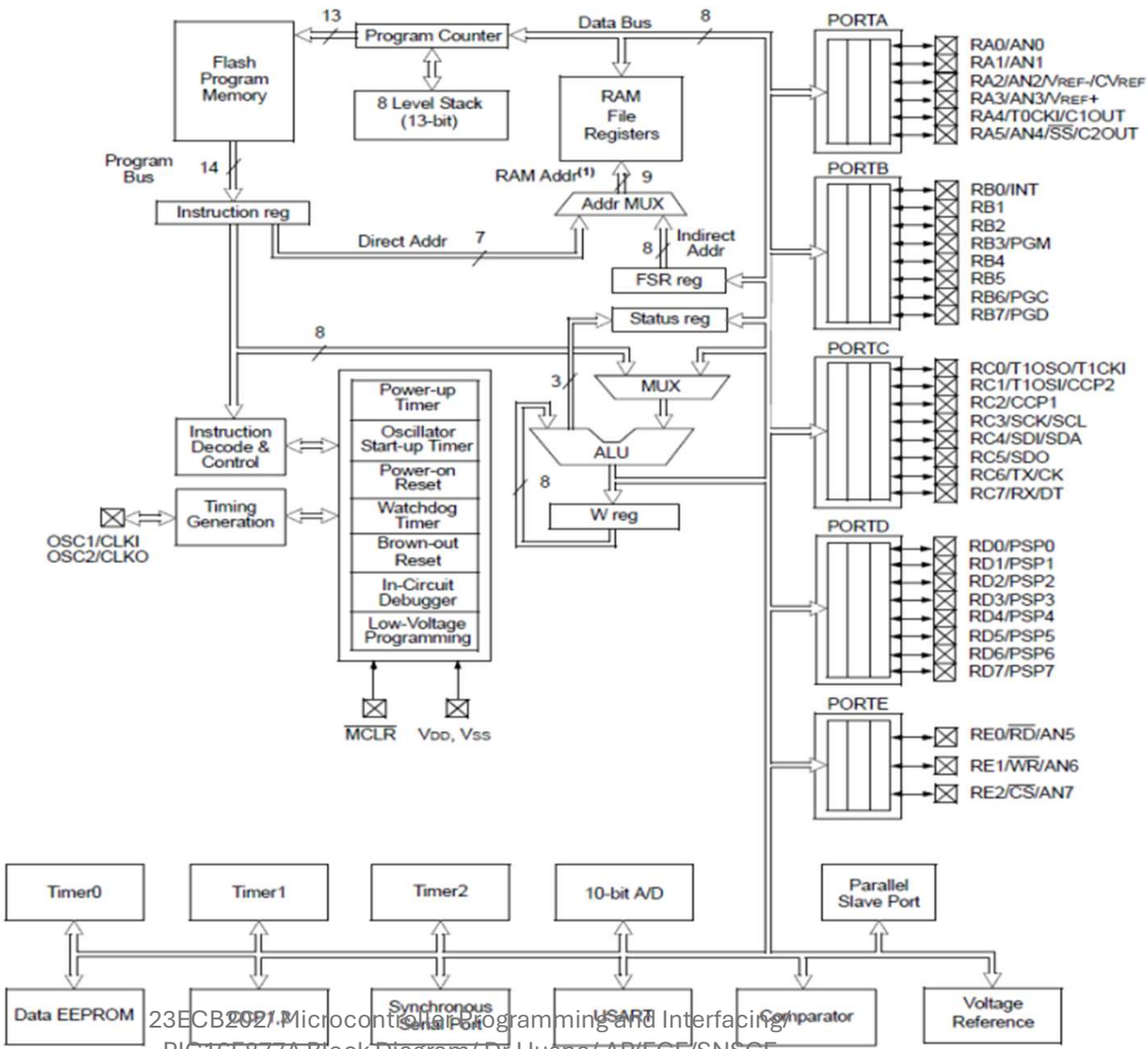

23ECB2021-Microcontroller Programming and Interfacing
 PIC16F877A Block Diagram/ Dr. Husna/ AP/ECE/SNSCE

PIC16F877A Block Diagram

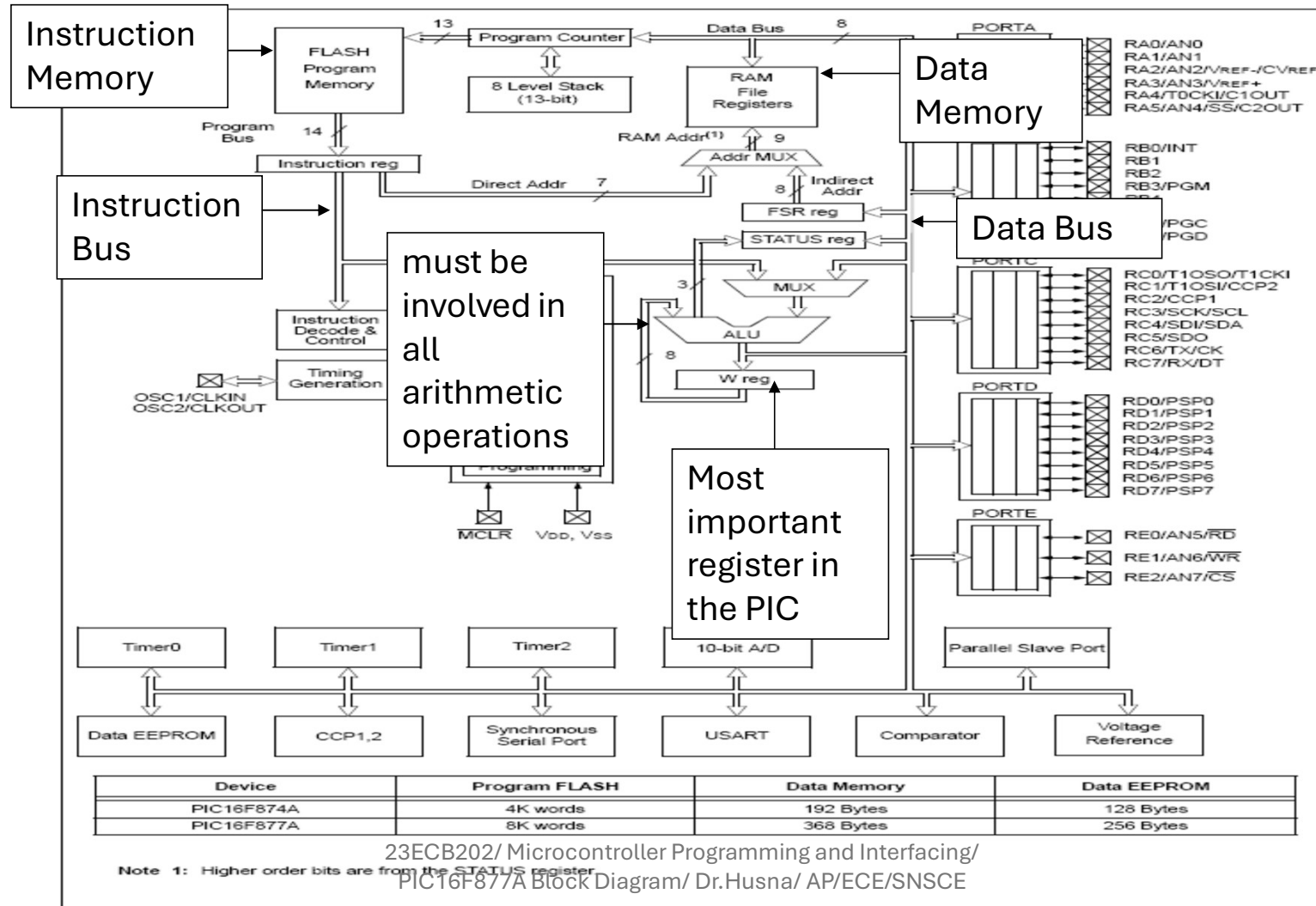



PIC16F877A Block Diagram

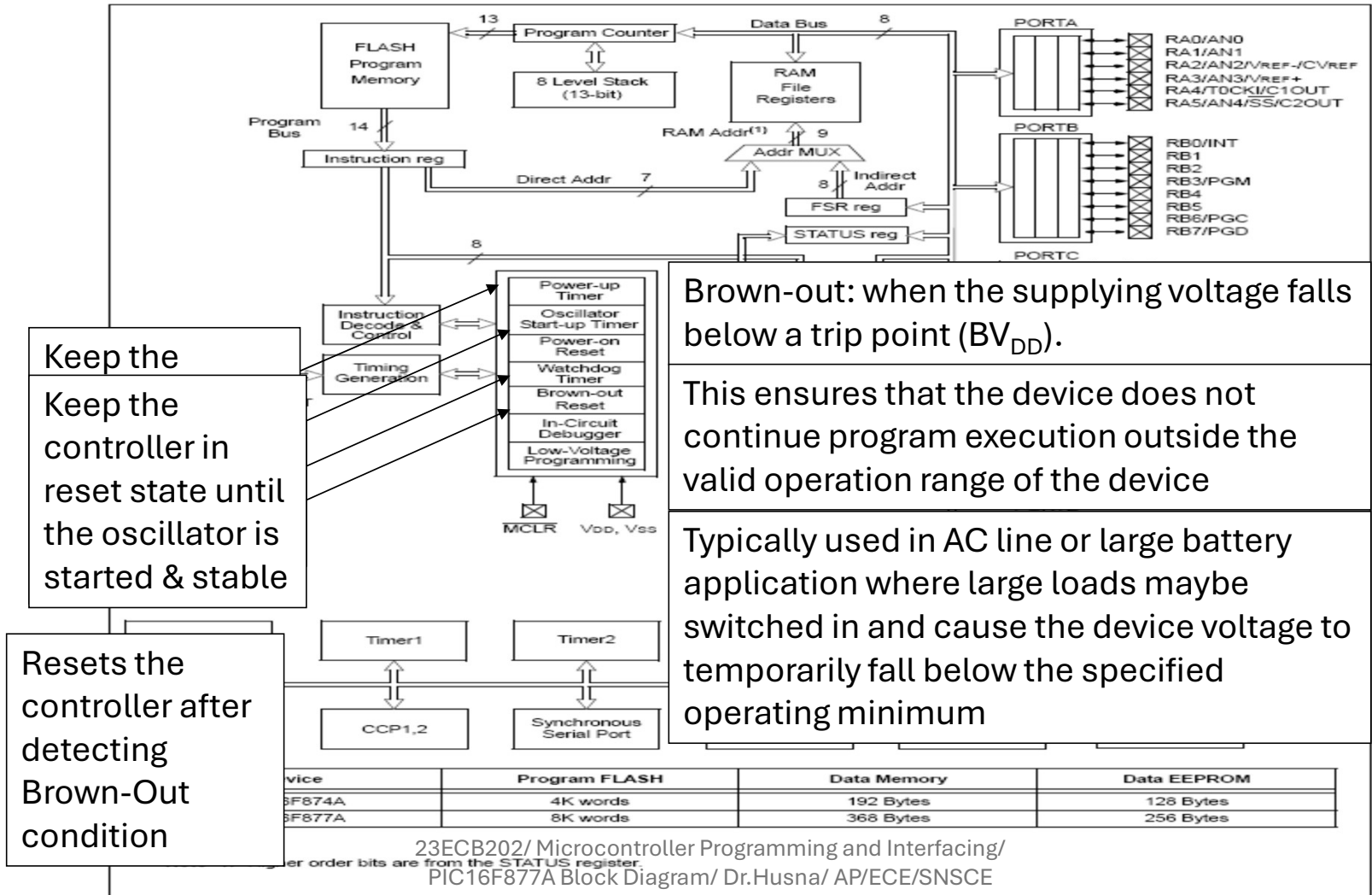

23ECB202/ Microcontroller Programming and Interfacing/
 PIC16F877A Block Diagram/ Dr.Husna/ AP/ECE/SNSCE