

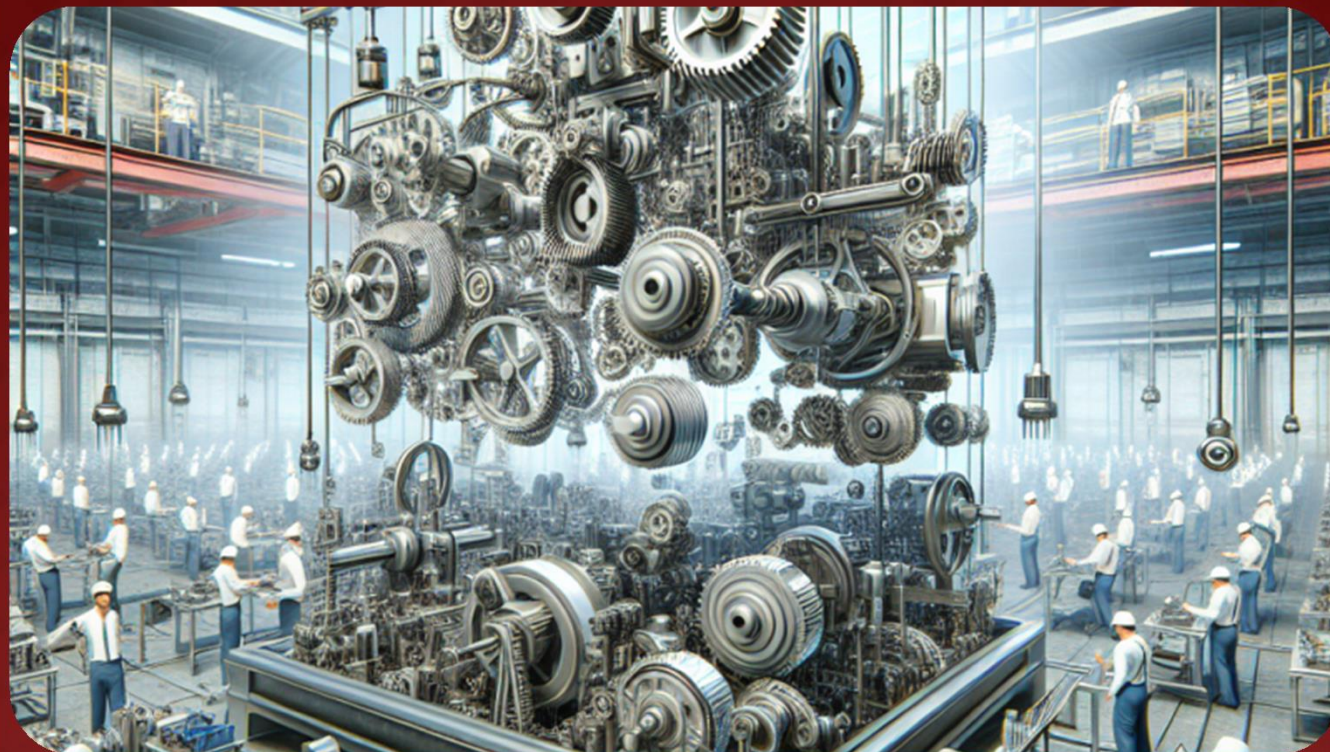

# 23MET204 MECHANICS OF MACHINES



## INVERSIONS OF SINGLE SLIDER CRANK MECHANISM

Presented by

**B.Balamurali**  
AP/MECH



# RECAP !!!



# INVERSIONS OF SINGLE SLIDER CRANK MECHANISM

**Single Slider Crank Mechanisms** - A single slider crank chain consist of one sliding pair and three turning pair. It is used to convert reciprocating motion into rotary motion and vice versa.

**The four links of single slider crank chain are :**

1. **Frame** : The fixed link is known as frame.
2. **Crank** : A link that makes complete revolutions is called as crank.
3. **Connecting Rod** : The link opposite to the fixed link is known as connecting rod.
4. **Slider** : A link that reciprocates is called as slider.

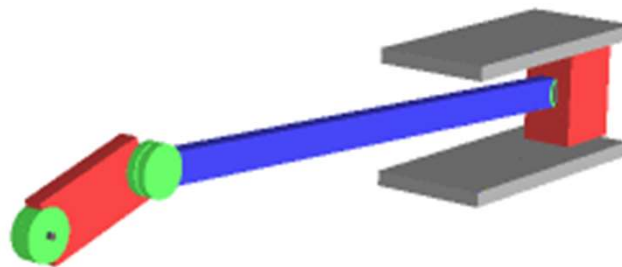

# INVERSIONS OF SINGLE SLIDER CRANK MECHANISM

## First Inversion :

Link 1 – Fixed;

Link 2 – Rotates;

Link 3 – Oscillates;

Link 4 – Reciprocates.

## Practical Applications :

- Internal Combustion Engine
- Steam Engine
- Reciprocating Compressor
- Reciprocating Pump

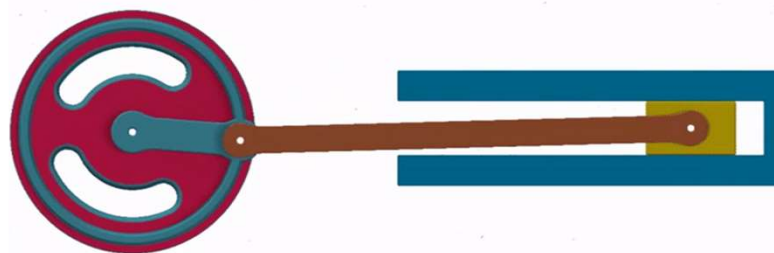
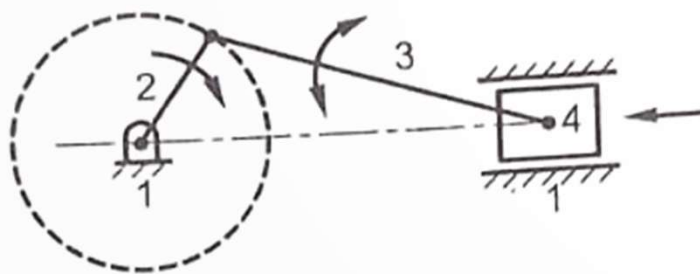

# INVERSIONS OF SINGLE SLIDER CRANK MECHANISM

## Second Inversion :

Link 1 – Oscillates;

Link 2 – Fixed;

Link 3 – Rotates;

Link 4 – Reciprocates.

## Practical Applications :

- Whitworth quick return motion mechanism
- Rotary or Gnone engine

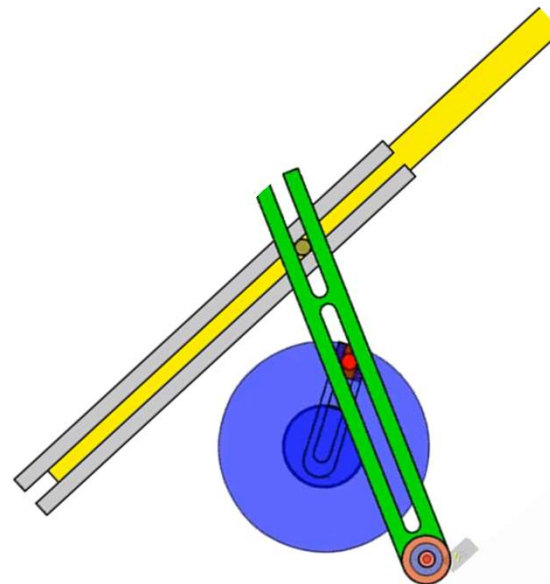
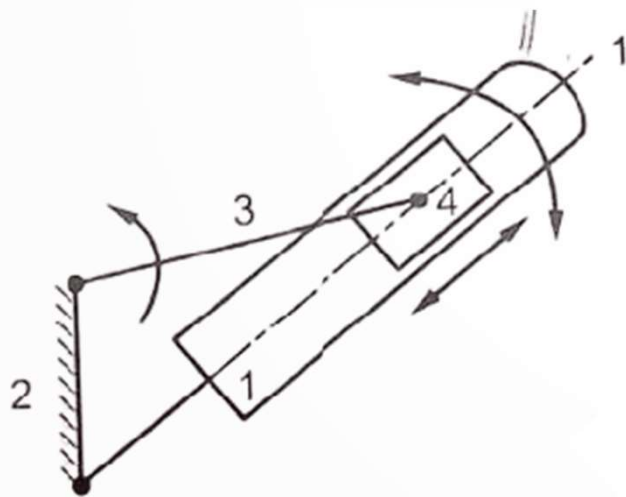

# INVERSIONS OF SINGLE SLIDER CRANK MECHANISM

## Third Inversion :

Link 1 – Oscillates;

Link 2 – Rotates;

Link 3 – Fixed;

Link 4 – Reciprocates.

## Practical Applications :

- Crank and Slotted lever quick return mechanism
- Oscillating cylinder engine

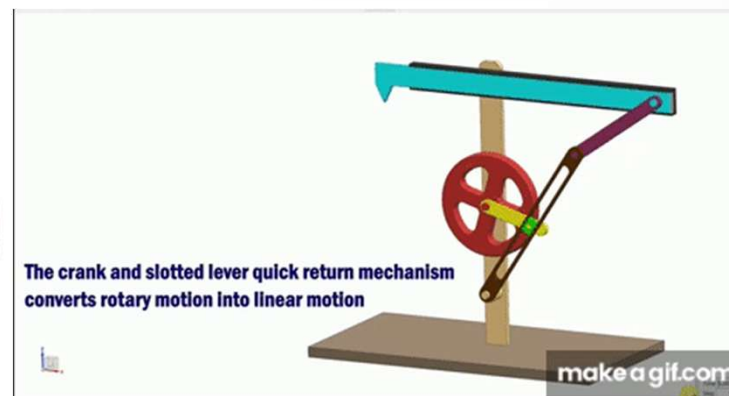
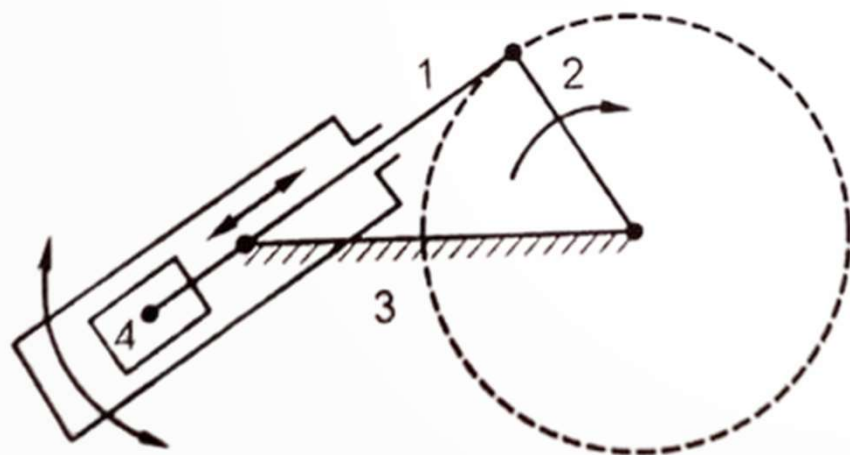

# INVERSIONS OF SINGLE SLIDER CRANK MECHANISM

## Fourth Inversion :

Link 1 –Reciprocates;

Link 2 –Rotates;

Link 3 – Oscillates;

Link 4 – Fixed.

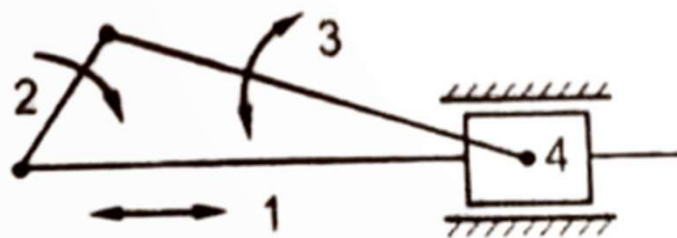

## Practical Applications :

- Pendulum pump or Bull engine
- Hand pump

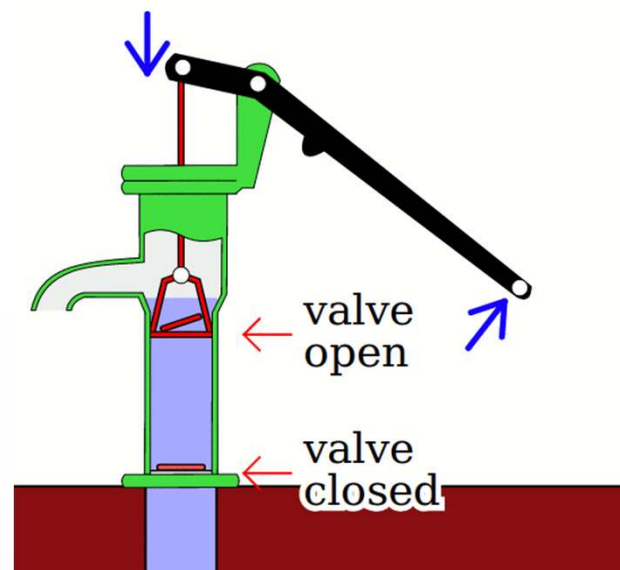



# ASSESSMENT !!!