



SNS COLLEGE OF ENGINEERING

Kurumbapalayam (Po), Coimbatore – 641 107

An Autonomous Institution

Accredited by NBA – AICTE and Accredited by NAAC – UGC with ‘A’ Grade
Approved by AICTE, New Delhi & Affiliated to Anna University, Chennai

DEPARTMENT OF ELECTRONICS AND COMMUNICATION ENGINEERING

**COURSE NAME : 19EC513 – IMAGE PROCESSING AND COMPUTER
VISION**

III YEAR / V SEMESTER

Unit III- IMAGE COMPRESSION AND IMAGE SEGMENTATION

Topic : Image compression and Need for compression

Image compression and Need for compression / 19EC513/ IMAGE PROCESSING AND COMPUTER VISION
/Mr.S.HARIBABU/ECE/SNSCE

The compression of images is an important step before we start the processing of larger images or videos. The compression of images is carried out by an encoder and output a compressed form of an image. In the processes of compression, the mathematical transforms play a vital role. A flow chart of the process of the compression of the image can be represented as



Why Do We Need Image Compression?

Consider a black and white image that has a resolution of 1000×1000 and each pixel uses 8 bits to represent the intensity. So the total no of bits required = $1000 \times 1000 \times 8 = 80,00,000$ bits per image.

And **consider if it is a video with 30 frames per second of the above-mentioned type images then the total bits for a video of 3 secs is: $3 \times (30 \times (8,000,000)) = 720,000,000$ bits**



As we see just to store a 3-sec video we need so many bits which is very huge. So, we need a way to have proper representation as well to store the information about the image in a minimum no of bits without losing the character of the image. Thus, image compression plays an important role.

Basic steps in image compression:

- Applying the image transform
- Quantization of the levels
- Encoding the sequences.

Transforms in Image Processing

The image is also a function of the location of the pixels. i.e $I(x, y)$ where (x, y) are the coordinates of the pixel in the image. So we generally transform an image from the spatial domain to the frequency domain.

Why Transformation of the Image is Important:

It becomes easy to know what all the principal components that make up the image and help in the compressed representation.

- It makes the computations easy.

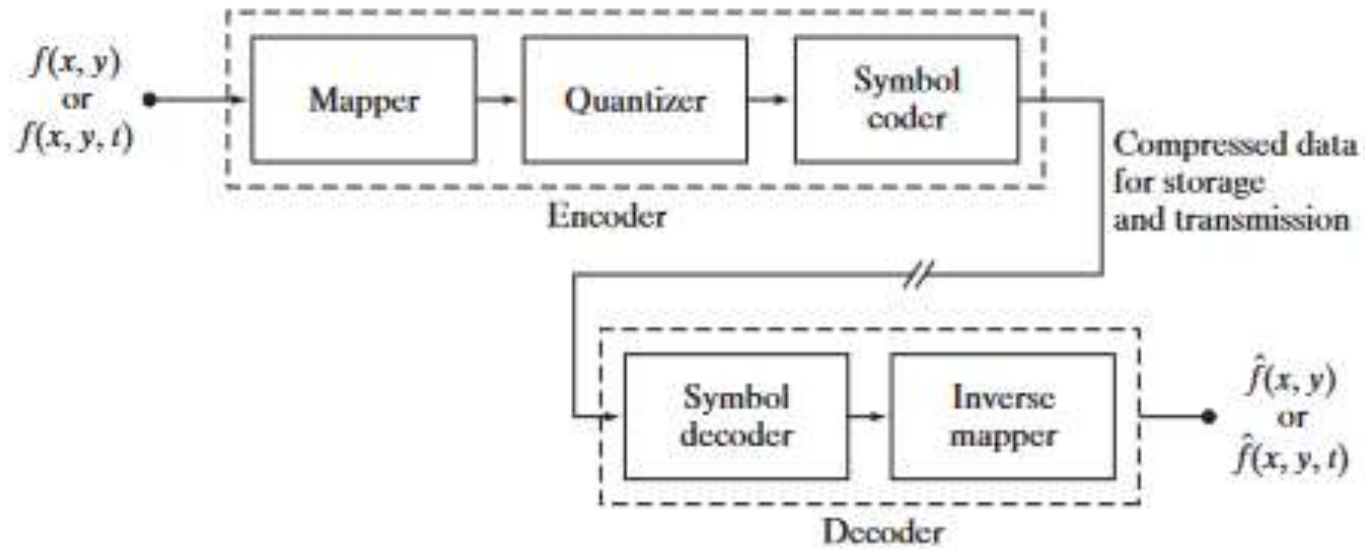

- Example: finding convolution in the time domain before the transformation

$$(f * g)(t) \triangleq \int_{-\infty}^{\infty} f(\tau)g(t - \tau) d\tau.$$

Finding convolution in the frequency domain after the transformation:

$$(f * g)(t) = F(s)G(s)$$



THANK YOU !!!