



SNS COLLEGE OF ENGINEERING



Kurumbapalayam(Po), Coimbatore – 641 107

Accredited by NAAC-UGC with 'A' Grade

Approved by AICTE, Recognized by UGC & Affiliated to Anna University, Chennai

Department of Information Technology

Course Name – 19IT401 Computer Networks

II Year / IV Semester

Unit 2 – Link Layer

Topic 5- Media Access

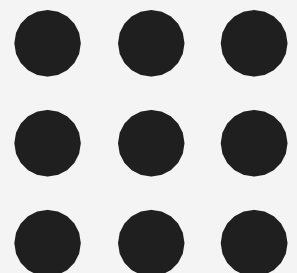

Media Access Control

Taxonomy of multiple-access protocols

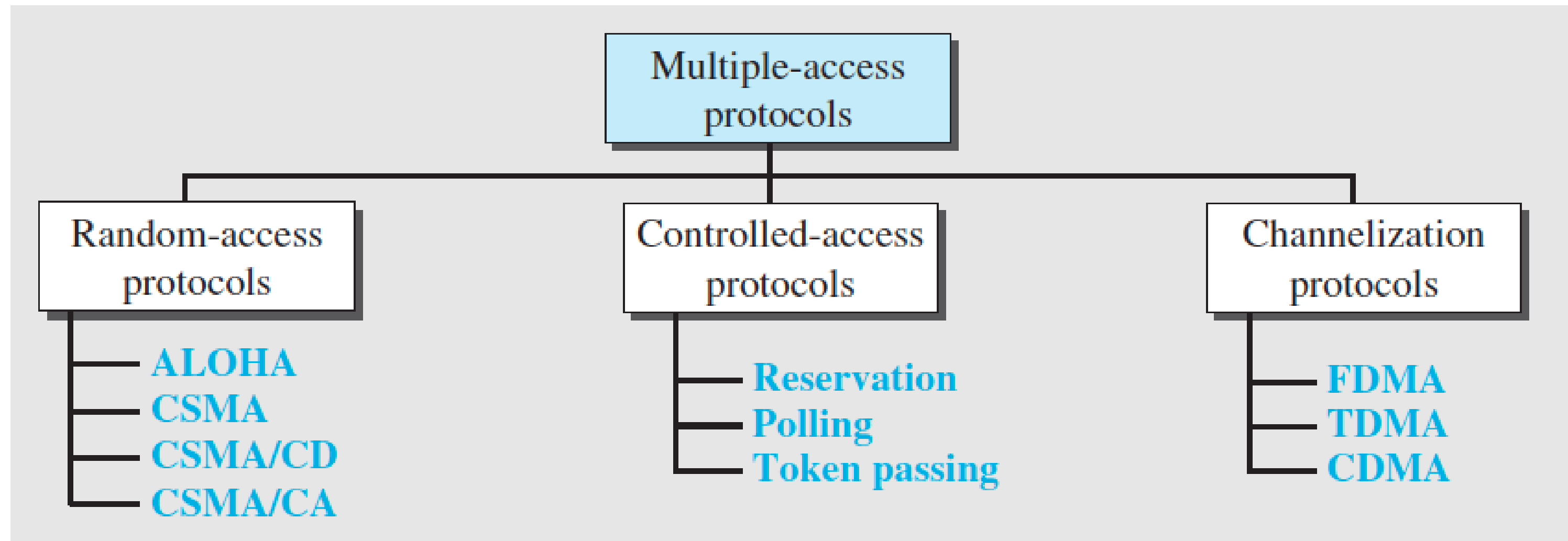

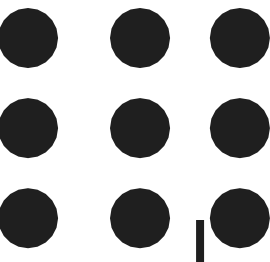

MAC Controlled Access

Controlled Access

In controlled access, the stations consult one another to find which station has the right to send. A station cannot send unless it has been authorized by other stations.

Reservation

- In the reservation method, a station needs to make a reservation before sending data.
- Time is divided into intervals. In each interval, a reservation frame precedes the data frames sent in that interval.
- If there are N stations in the system, there are exactly N reservation minislots in the reservation frame.
- Each minislot belongs to a station. When a station needs to send a data frame, it makes a reservation in its own minislot.
- The stations that have made reservations can send their data frames after the reservation frame.

MAC - Reservation

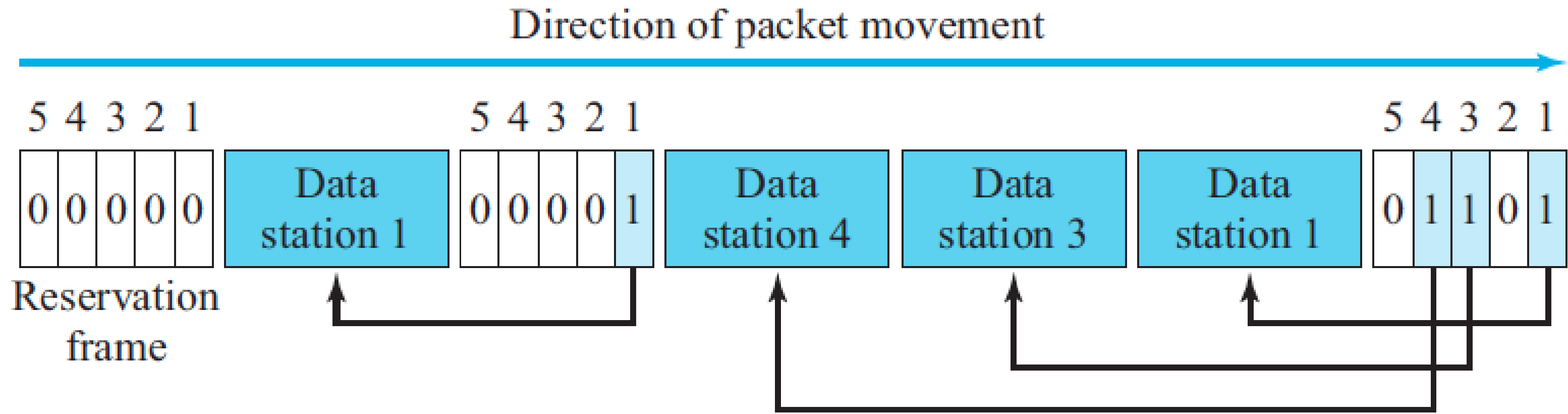

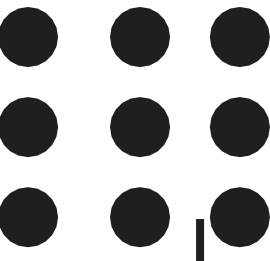

MAC - Polling

Polling

- Polling works with topologies in which one device is designated as a primary station and the other devices are secondary stations .
- All data exchanges must be made through the primary device even when the ultimate destination is a secondary device.
- The primary device controls the link; the secondary devices follow its instructions.
- It is up to the primary device to determine which device is allowed to use the channel at a given time.
- The primary device, therefore, is always the initiator of a session
- This method uses poll and select functions to prevent collisions. However, the drawback is if the primary station fails, the system goes down.

MAC - Polling

Select

- The select function is used whenever the primary device has something to send.
- If primary station has something to send, it sends data.
- What it does not know, however, is whether the target device is prepared to receive.
- So the primary must alert the secondary to the upcoming transmission and wait for an acknowledgment of the secondary's ready status.
- Before sending data, the primary creates and transmits a select (SEL) frame, one field of which includes the address of the intended secondary.

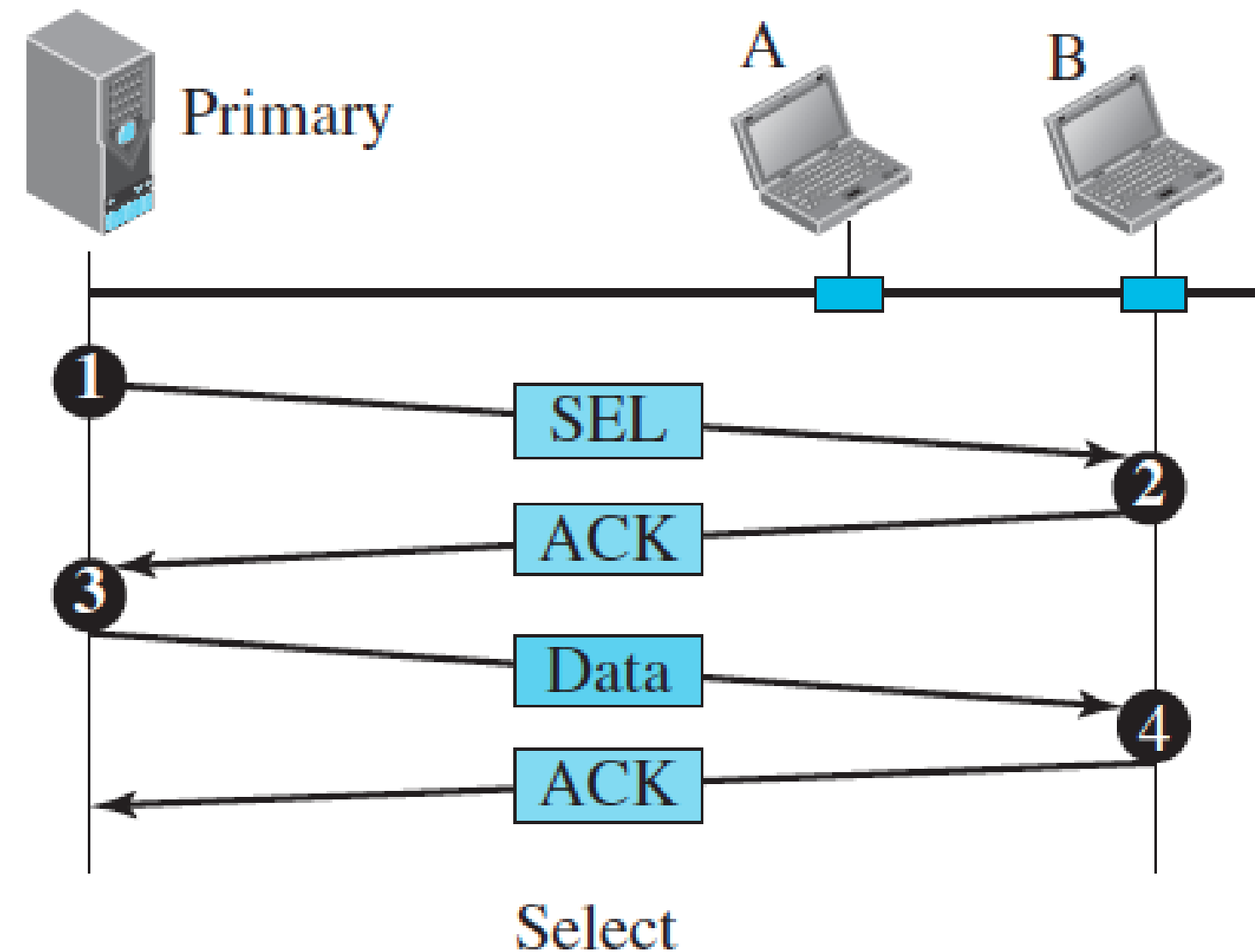

MAC - Polling

Poll

- The poll function is used by the primary device to solicit transmissions from the secondary devices. When the primary is ready to receive data, it must ask (poll) each device in turn if it has anything to send.
- When the first secondary is approached, it responds either with a NAK frame if it has nothing to send or with data (in the form of a data frame) if it does.
- If the response is negative (a NAK frame), then the primary polls the next secondary in the same manner until it finds one with data to send.
- When the response is positive (a data frame), the primary reads the frame and returns an acknowledgment (ACK frame), verifying its receipt.

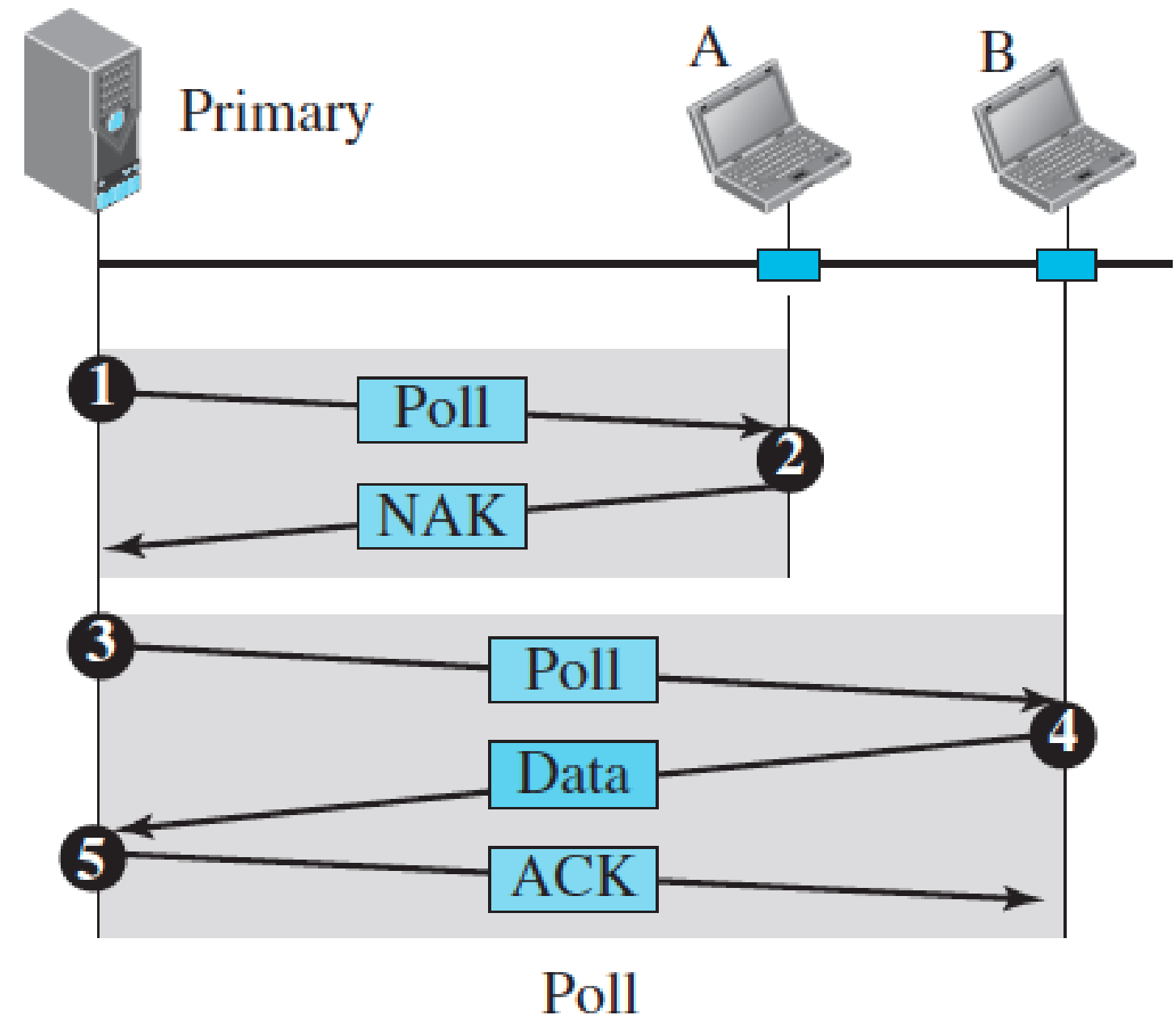

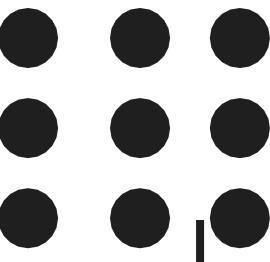

MAC – Token Passing

Token Passing

- In the token-passing method, the stations in a network are organized in a logical ring. In other words, for each station, there is a predecessor and a successor.
- The right to this access has been passed from the predecessor to the current station. The right will be passed to the successor when the current station has no more data to send.
- In this method, a special packet called a token circulates through the ring.
- The possession of the token gives the station the right to access the channel and send its data.
- When a station has some data to send, it waits until it receives the token from its predecessor.
- It then holds the token and sends its data. When the station has no more data to send, it releases the token, passing it to the next logical station in the ring.

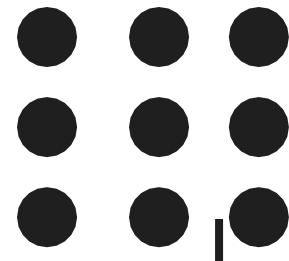

MAC - Token Passing

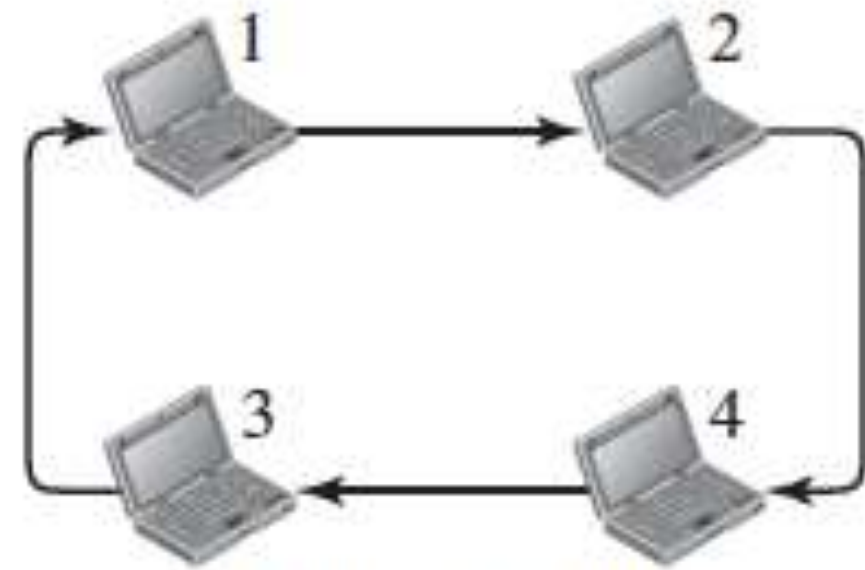

a. Physical ring

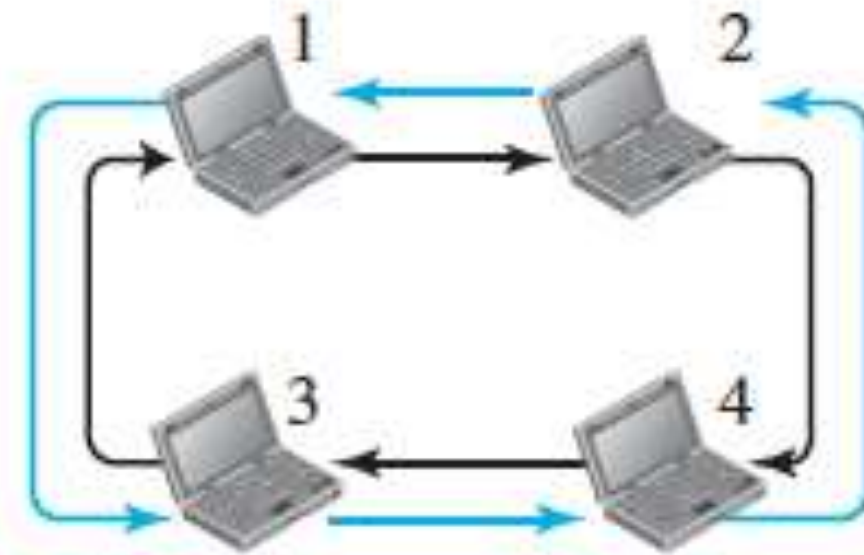

b. Dual ring

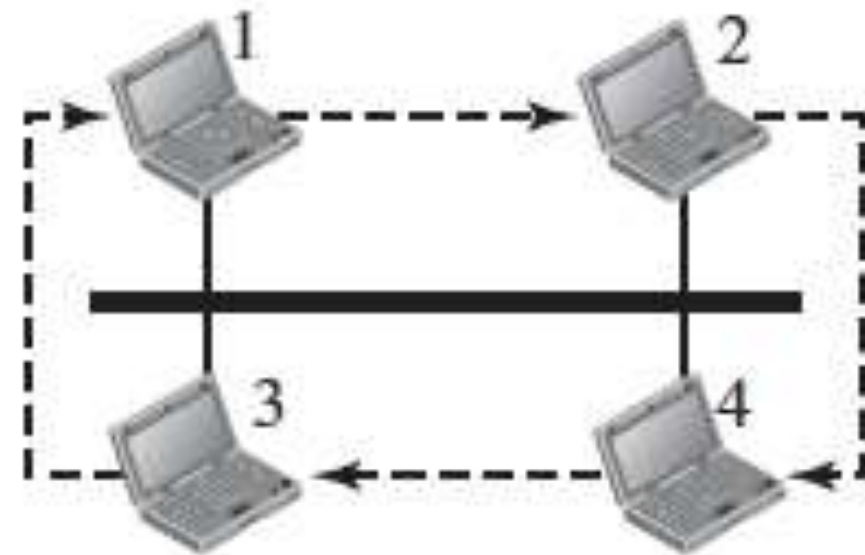

c. Bus ring



d. Star ring

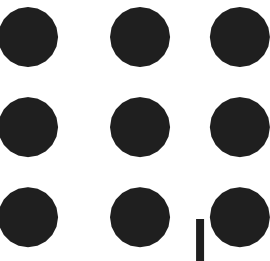

CHANNEL ACCESS SCHEMES

Channelization is a multiple-access method in which the available bandwidth of a link is shared in time, frequency, or through code, among different stations.

Types

- Frequency Division Multiple Access (FDMA)
- Time division multiple access (TDMA)
- Code division multiple access (CDMA)

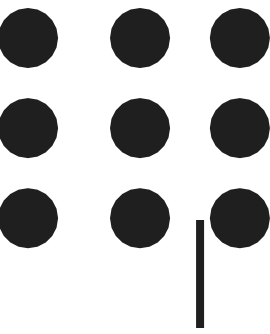

FDMA

Frequency Division Multiple Access (FDMA)

- In frequency-division multiple access (FDMA), the available bandwidth is divided into frequency bands.
- Each station is allocated a band to send its data. In other words, each band is reserved for a specific station, and it belongs to the station all the time.
- Each station also uses a bandpass filter to confine the transmitter frequencies.
- To prevent station interferences, the allocated bands are separated from one another by small guard bands.

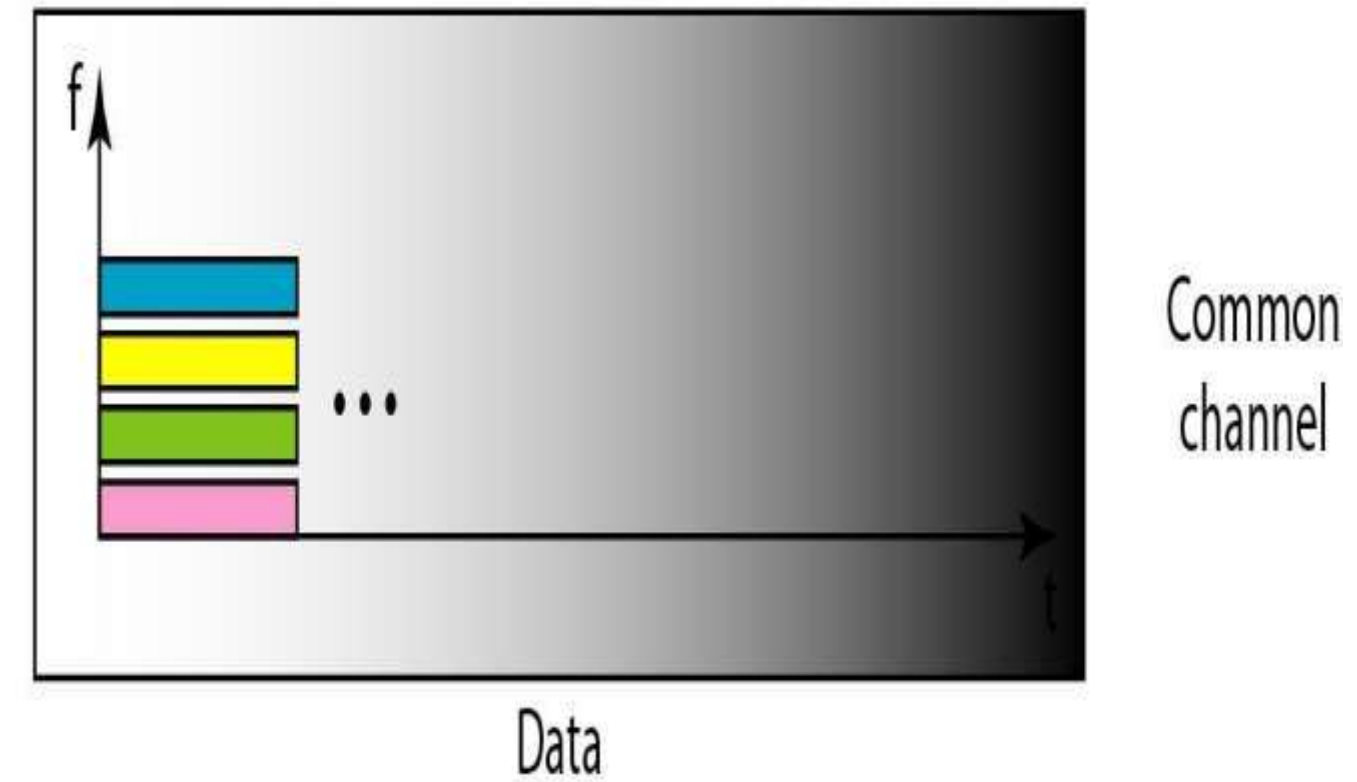

FDMA

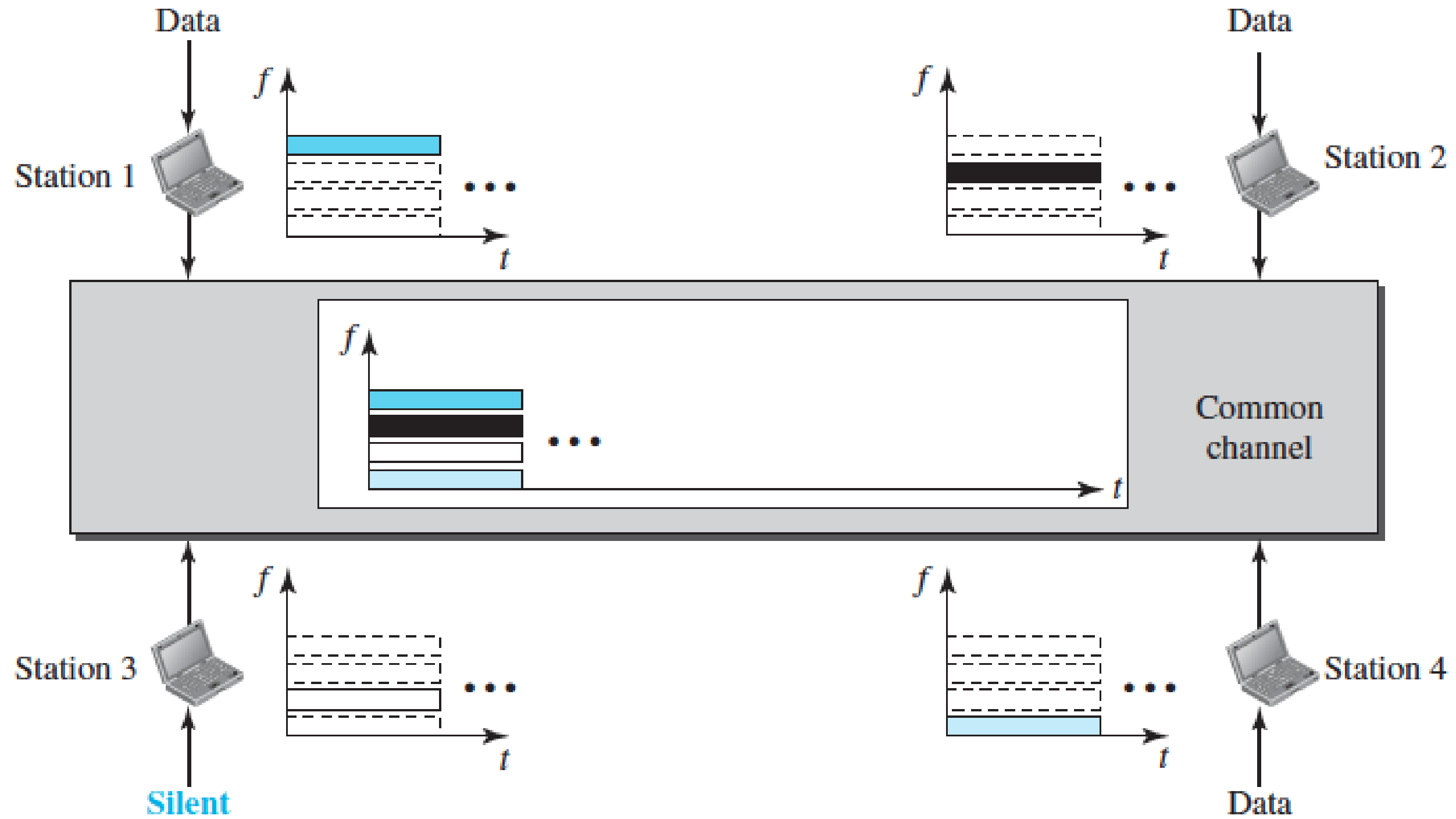

TDMA

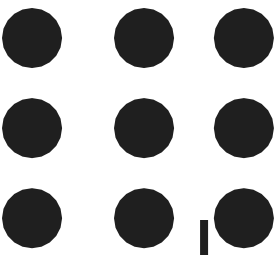

Time-division multiple access

- In time-division multiple access (TDMA), the stations share the bandwidth of the channel in time.
- Each station is allocated a time slot during which it can send data.
- Each station transmits its data in its assigned time slot.
- The main problem with TDMA lies in achieving synchronization between the different stations.
- Each station needs to know the beginning of its slot and the location of its slot.
- Synchronization is normally accomplished by having some synchronization bits (normally referred to as preamble bits) at the beginning of each slot.



Common
channel

TDMA

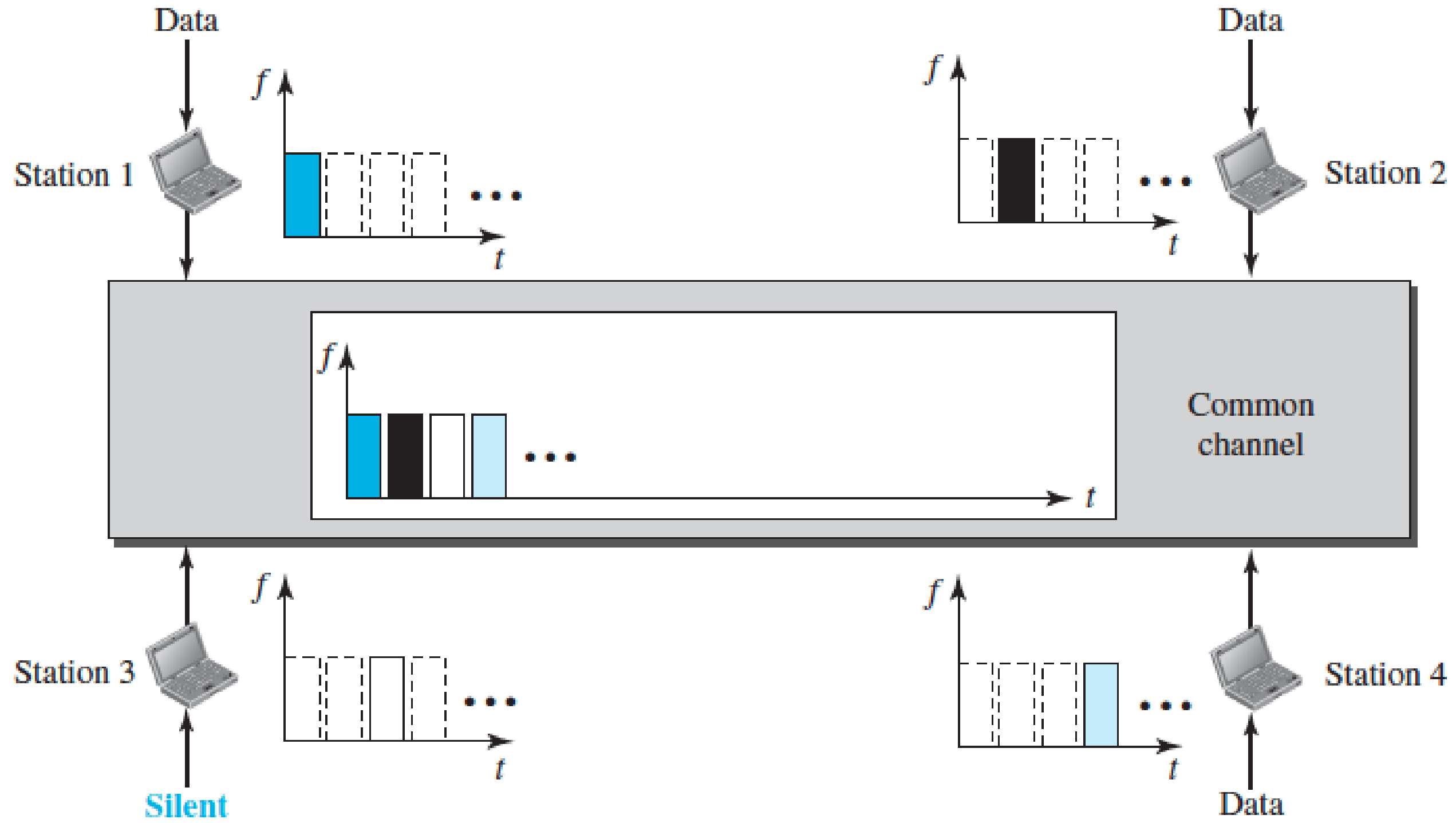



CDMA



Code-division multiple access (CDMA)

CDMA differs from FDMA in that only one channel occupies the entire bandwidth of the link. It differs from TDMA in that all stations can send data simultaneously.

CDMA simply means communication with different codes.

For example, in a large room with many people, two people can talk privately in English if nobody else understands English.

Another two people can talk in Chinese if they are the only ones who understand Chinese, and so on.

In other words, the common channel, the space of the room in this case, can easily allow communication between several couples, but in different languages.

CDMA is based on coding theory. Each station is assigned a code, which is a sequence of numbers called chips. The codes are called orthogonal sequences.

CDMA

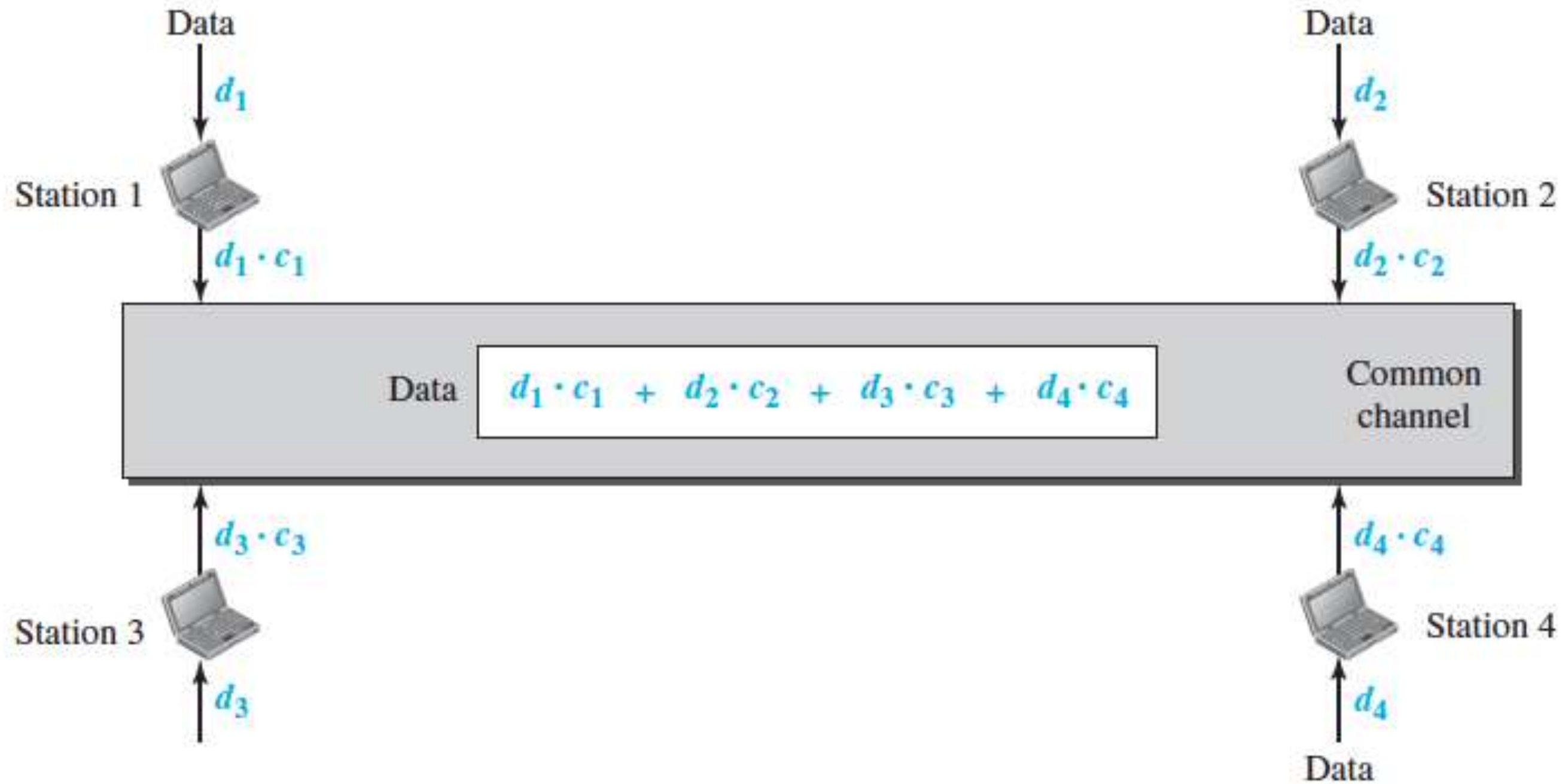



THANK YOU