



SNS College
of Engineering

SNS COLLEGE OF ENGINEERING

Coimbatore
An Autonomous Institution



Accredited by NBA – AICTE and Accredited by NAAC – UGC with 'A+' Grade
Approved by AICTE, New Delhi & Affiliated to Anna University, Chennai

DEPARTMENT OF ELECTRICAL AND ELECTRONICS ENGINEERING

19EET301 / POWER ELECTRONICS AND DRIVES

V SEM EEE

UNIT 3 –AC CONVERTERS

SINGLE PHASE INVERTER

Dr. C. UDHAYA SHANKAR

ASP/EEE, SNSCE



SNS College of Engineering

APPLICATION



Intro-Inverter

Inverter is defined as an Electrical device which converts the Direct current source into the Alternating current source.



The main source of electrical power is the battery which is a DC source. The DC output of the battery is bucked or boosted according to the requirement and then converted into AC using a DC-AC inverter.

Types of inverter-

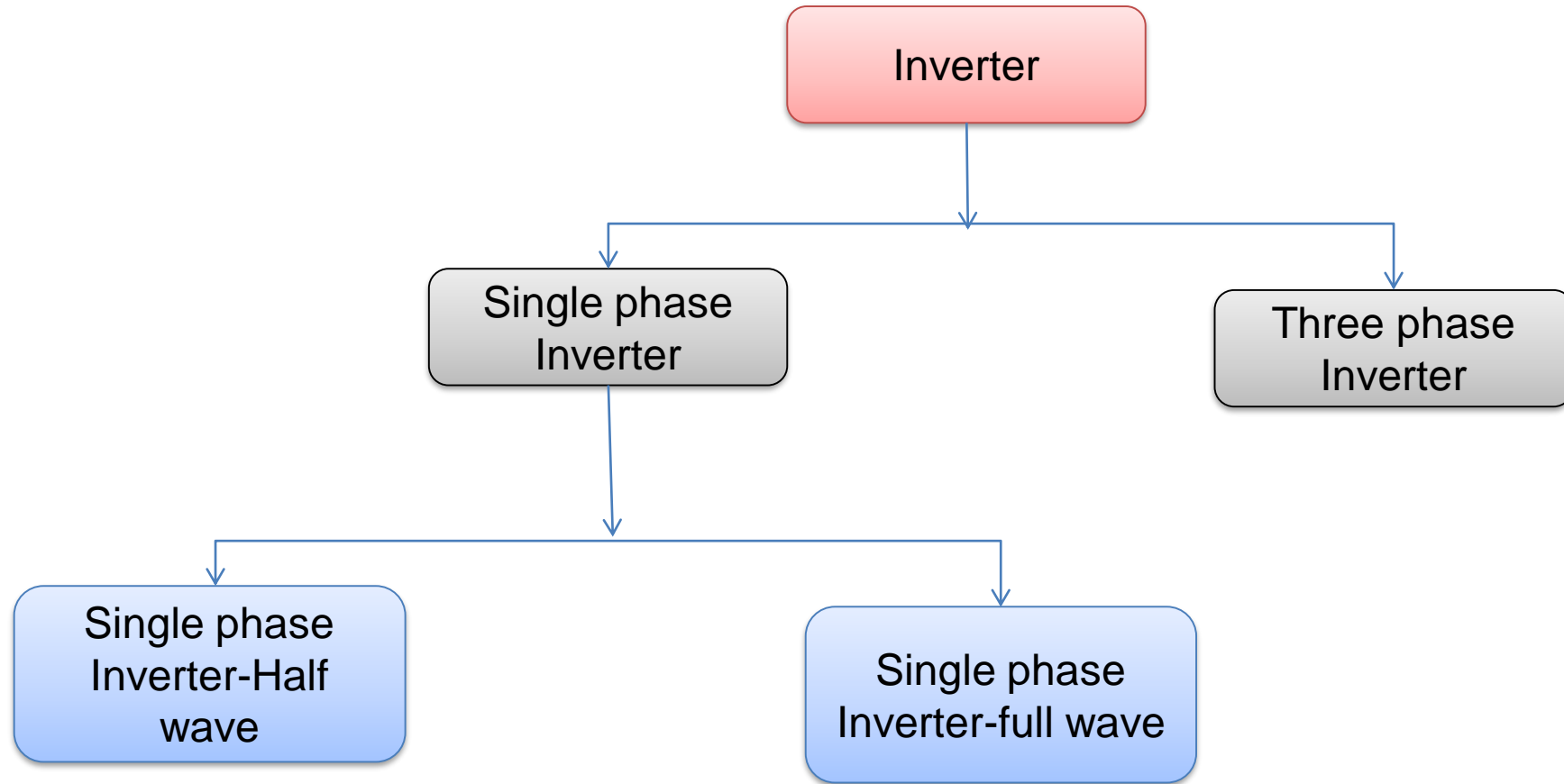

INVERTERS



Inverter is a device which converts DC to AC power at desired output voltage and frequency.

Classification based on Nature of source:

Voltage Fed Inverter (VFI or VSI) and Current Fed Inverter (CFI or CSI).

VSI - negligibly small source impedance so terminal voltage remains substantially constant for variations in load.

Short circuit causes current to rise instantaneously due to less time constant and current should be interrupted by Fast Acting Fuses.

CSI - supplies with controlled current from a DC source with large impedance.

Typically a rectifier feeds the inverter with a regulated current through large series inductor.

Classification based on wave shape of output:

- Square wave inverter
- Quasi Square wave inverter
- Pulse Width Modulated inverter

1-ph Half Bridge Inverter

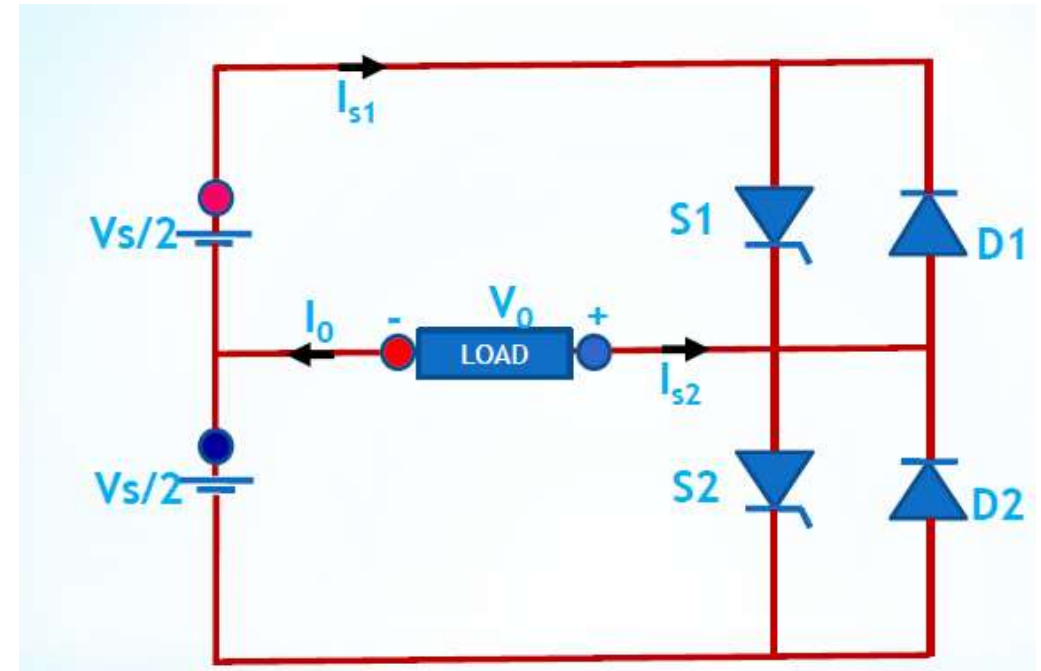
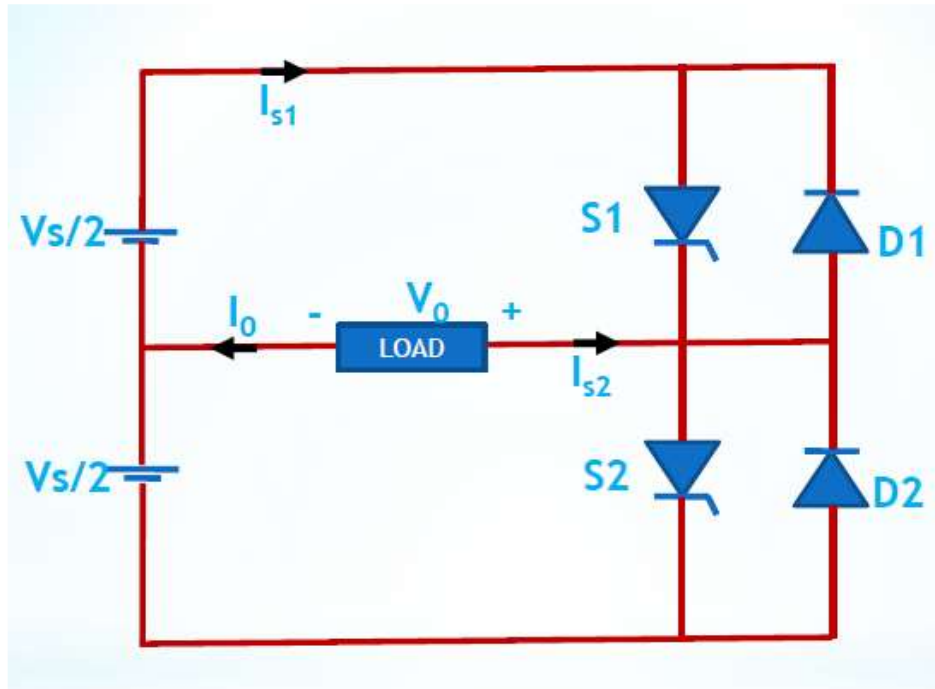

Mode 1: S1-ON, V_o is +ve, I_o is +ve, I_{s1} is +ve. Load takes power from source; $V_{T2}=V_s$, $V_{D1}=0V$, $V_{D2}= -V_s$.

Mode 2: S1-OFF, D2ON; V_o is -ve, I_o is +ve, I_{s2} is -ve; Load delivers power to source, $V_{T1}=V_s$, $V_{T2}=0V$, $V_{D1}=-V_s$.

Mode 3: S2-ON, V_o is -ve, I_o is -ve, I_{s2} is +ve. Load takes power from source; $V_{T1}=V_s$, $V_{D1}= -V_s$, $V_{D2}=0V$.

Mode 4: S2-OFF, D1 ON; V_o is +ve, I_o is -ve, I_{s1} is -ve; Load delivers power to source, $V_{T1}=0V$, $V_{T2}=V_s$, $V_{D2}=-V_s$.

1-ph Half Bridge Inverter-Waveforms

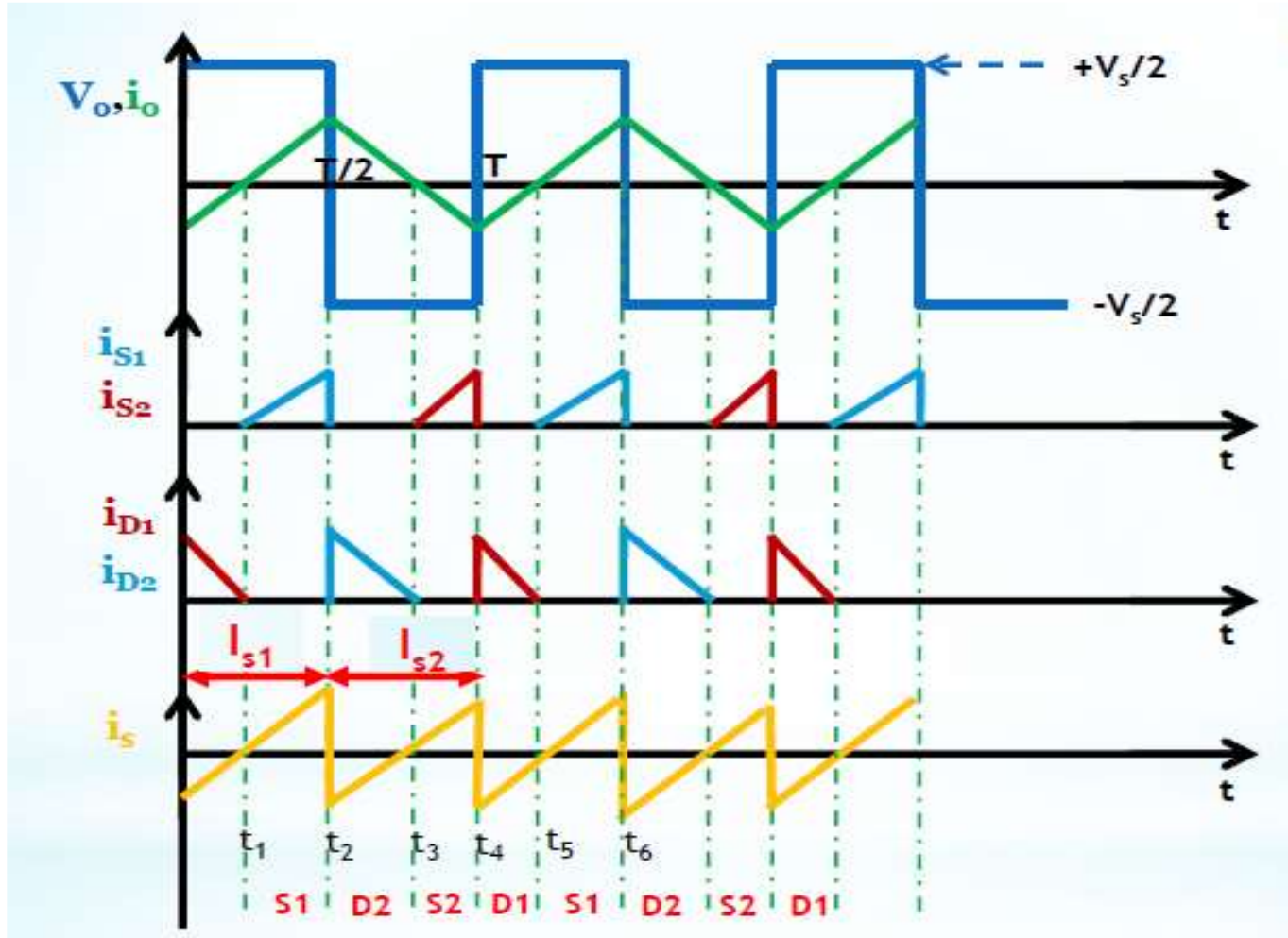

$$V_o(rms) = \frac{1}{T_0/2} \int_0^{T_0/2} \frac{V_s^2}{4} dt = \frac{V_s}{2}$$

1-ph Full Bridge Inverter-Schematic

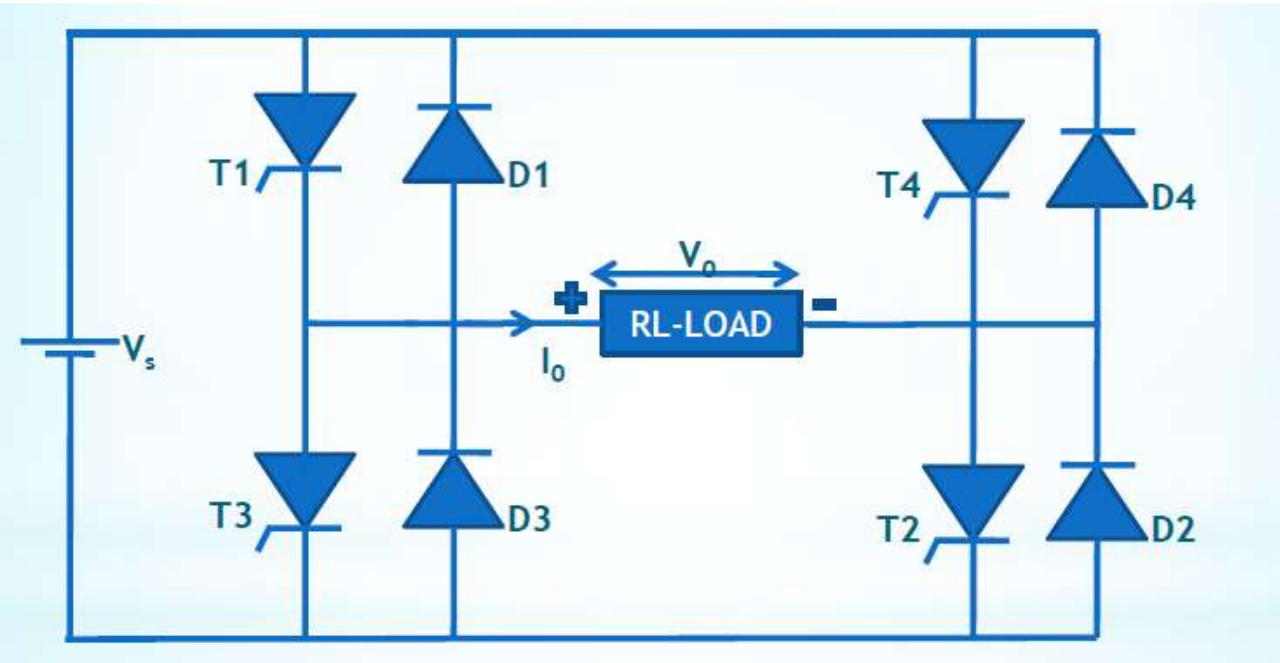

MODE 1: T1, T2 ON, SOURCE DELIVERING POWER TO LOAD –
 V_o +ve, I_o +ve.

MODE 2: FREE WHEELING INTERVAL, LOAD DELIVERING
POWER TO SOURCE
THROUGH D3, D4 – V_o –ve, I_o +ve.

MODE 3: T3, T4 ON, SOURCE DELIVERING POWER TO LOAD, V_o
–ve, I_o –ve.

MODE 4: FREE WHEELING INTERVAL, LOAD DELIVERING
POWER TO SOURCE
THROUGH D1, D2 – V_o +ve, I_o –ve.

1-ph Full Bridge Inverter- Wave forms



The rms output voltage is

$$V_0 = \left(\frac{2}{T_0} \int_0^{T/2} V_S^2 \right)^{1/2} = V_S$$

