



# **SNS COLLEGE OF ENGINEERING**

**An Autonomous Institution**

**Coimbatore-107**

## **19IT503-INTERNET OF THINGS**

**UNIT-1 IoT INTRODUCTION AND APPLICATIONS**  
**Department of Computer Science and Technology**

**Topic:8– IoT and M2M**

# Outline

- M2M
- Differences and Similarities between M2M and IoT
- SDN and NFV for IoT

# Machine-to-Machine (M2M)

- Machine-to-Machine (M2M) refers to networking of machines (or devices) for the purpose of remote monitoring and control and data exchange.

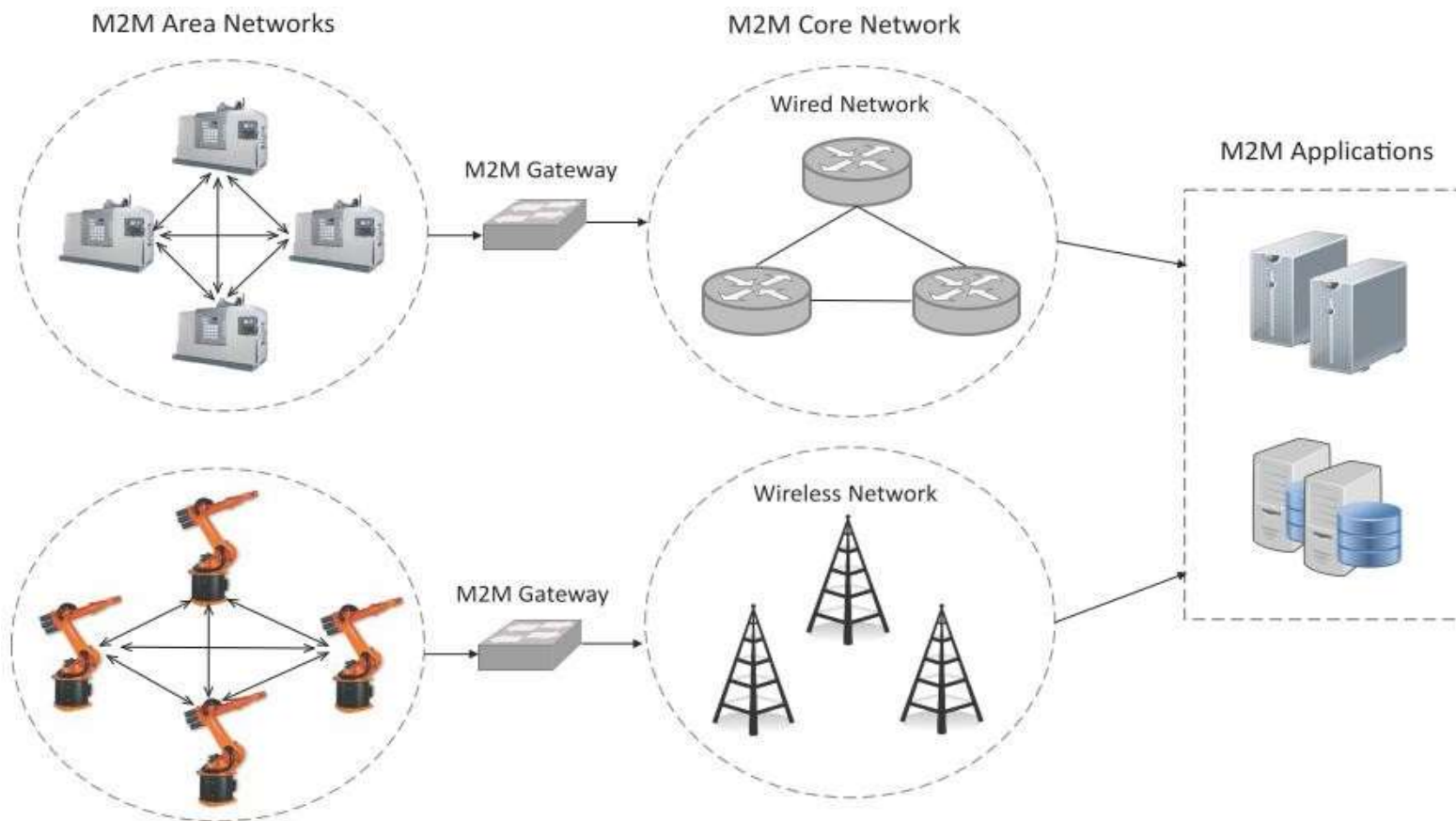

# Machine-to-Machine (M2M)

- An M2M area network comprises of machines (or M2M nodes) which have embedded hardware modules for sensing, actuation and communication.
- Various communication protocols can be used for M2M local area networks such as ZigBee, Bluetooth, ModBus, M-Bus, Wireless M-Bus, Power Line Communication (PLC), 6LoWPAN, IEEE 802.15.4, etc.
- The communication network provides connectivity to remote M2M area networks.
- The communication network can use either wired or wireless networks (IP-based).
- While the M2M area networks use either proprietary or non-IP based communication protocols, the communication network uses IP-based networks.

# M2M gateway

- Since non-IP based protocols are used within M2M area networks, the M2M nodes within one network cannot communicate with nodes in an external network.
- To enable the communication between remote M2M area networks, M2M gateways are used.

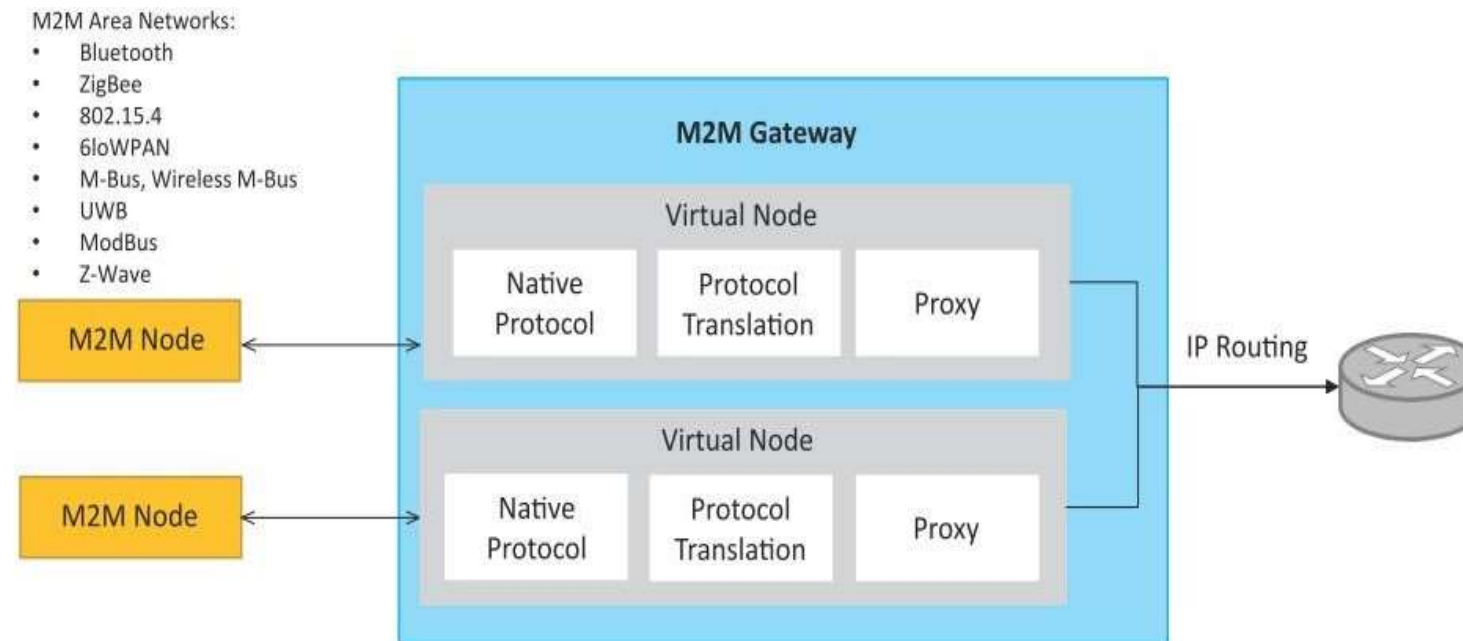

# Difference between IoT and M2M

- Communication Protocols
  - M2M and IoT can differ in how the communication between the machines or devices happens.
  - M2M uses either proprietary or non-IP based communication protocols for communication within the M2M area networks.
- Machines in M2M vs Things in IoT
  - The "Things" in IoT refers to physical objects that have unique identifiers and can sense and communicate with their external environment (and user applications) or their internal physical states.
  - M2M systems, in contrast to IoT, typically have homogeneous machine types within an M2M area network.

# Difference between IoT and M2M

- Hardware vs Software Emphasis
  - While the emphasis of M2M is more on hardware with embedded modules, the emphasis of IoT is more on software.
- Data Collection & Analysis
  - M2M data is collected in point solutions and often in on-premises storage infrastructure.
  - In contrast to M2M, the data in IoT is collected in the cloud (can be public, private or hybrid cloud).
- Applications
  - M2M data is collected in point solutions and can be accessed by on-premises applications such as diagnosis applications, service management applications, and on-premises enterprise applications.
  - IoT data is collected in the cloud and can be accessed by cloud applications such as analytics applications, enterprise applications, remote diagnosis and management applications, etc.

# Communication in IoT vs M2M

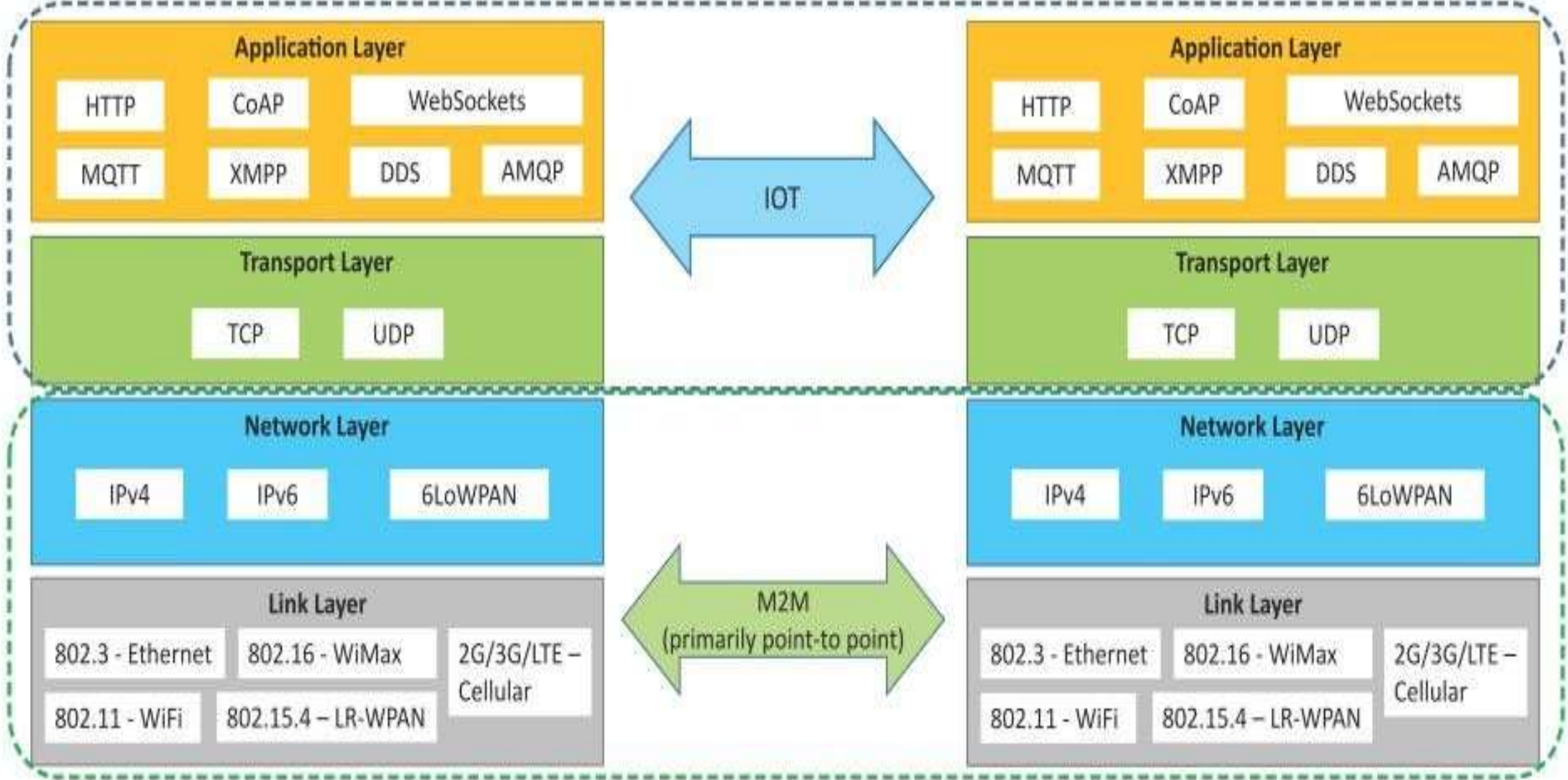



# SDN

- Software-Defined Networking (SDN) is a networking architecture that separates the control plane from the data plane and centralizes the network controller.
- Software-based SDN controllers maintain a unified view of the network and make configuration, management and provisioning simpler.
- The underlying infrastructure in SDN uses simple packet forwarding hardware as opposed to specialized hardware in conventional networks.

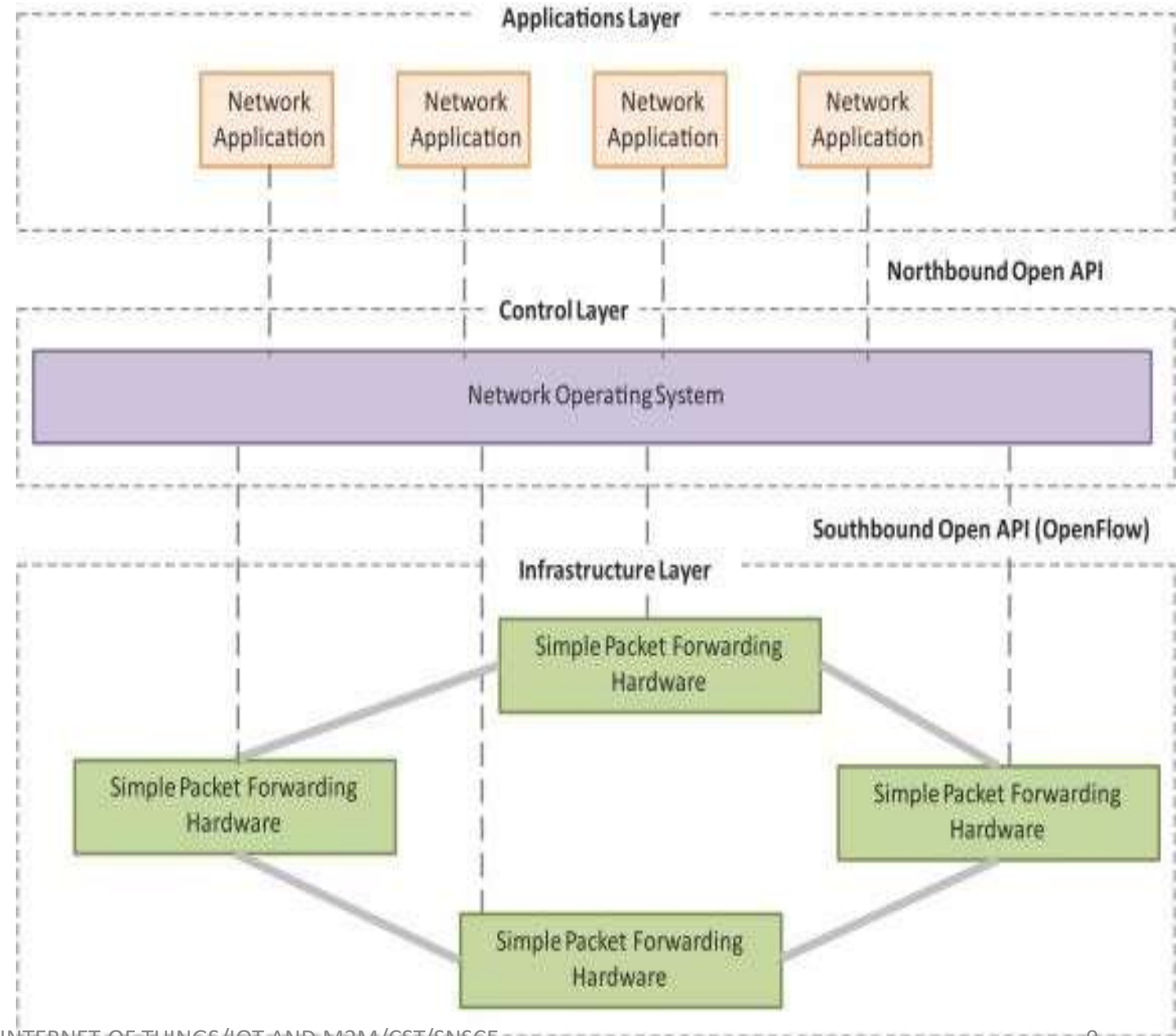

# Key elements of SDN

- Centralized Network Controller
  - With decoupled control and data planes and centralized network controller, the network administrators can rapidly configure the network.
- Programmable Open APIs
  - SDN architecture supports programmable open APIs for interface between the SDN application and control layers (Northbound interface).
- Standard Communication Interface (OpenFlow)
  - SDN architecture uses a standard communication interface between the control and infrastructure layers (Southbound interface).
  - OpenFlow, which is defined by the Open Networking Foundation (ONF) is the broadly accepted SDN protocol for the Southbound interface.

# NFV

- Network Function Virtualization (NFV) is a technology that leverages virtualization to consolidate the heterogeneous network devices onto industry standard high volume servers, switches and storage.
- NFV is complementary to SDN as NFV can provide the infrastructure on which SDN can run.

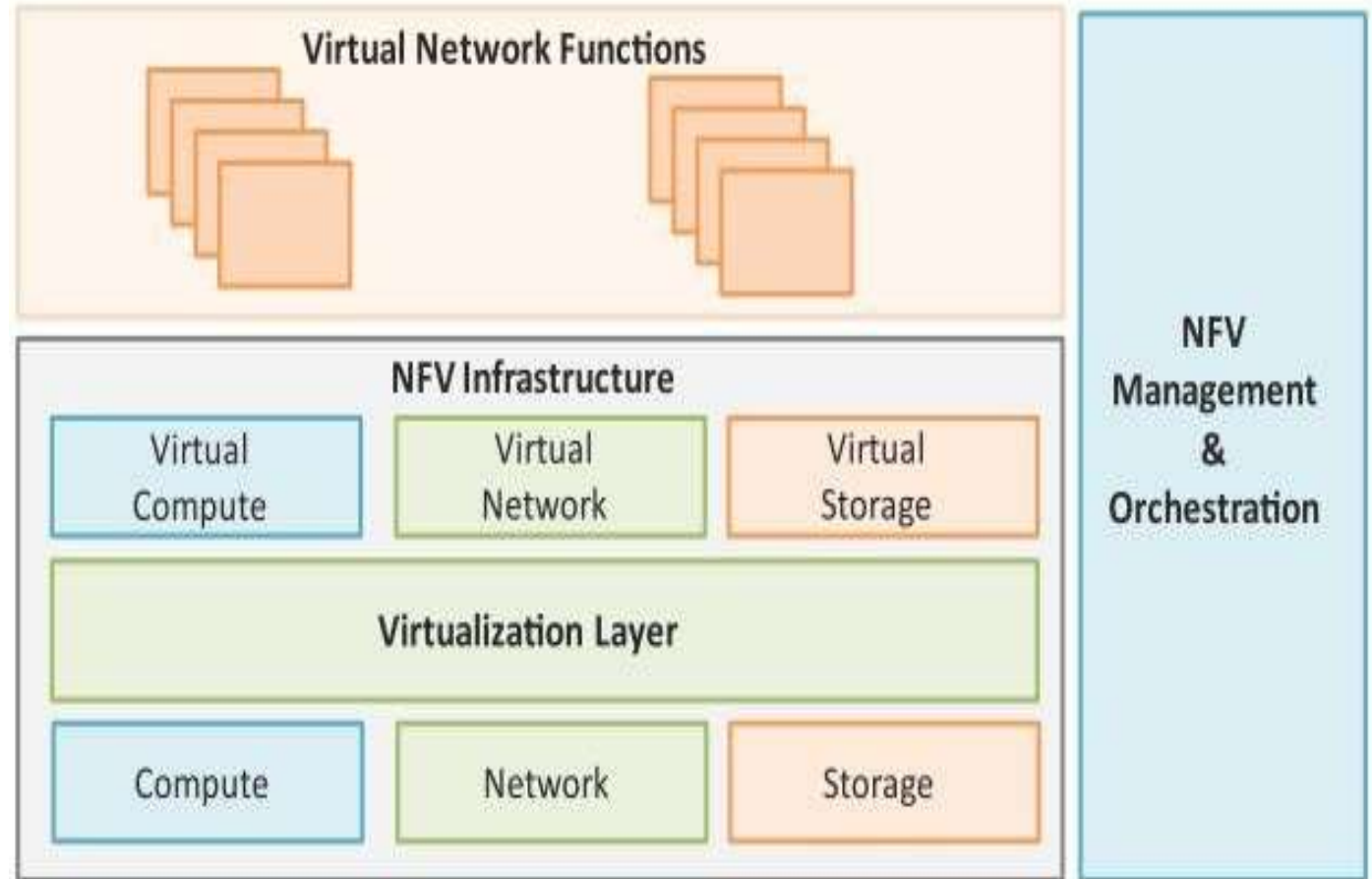

# Key elements of NFV

- Virtualized Network Function (VNF):
  - VNF is a software implementation of a network function which is capable of running over the NFV Infrastructure (NFVI).
- NFV Infrastructure (NFVI):
  - NFVI includes compute, network and storage resources that are virtualized.
- NFV Management and Orchestration:
  - NFV Management and Orchestration focuses on all virtualization-specific management tasks and covers the orchestration and life-cycle management of physical and/or software resources that support the infrastructure virtualization, and the life-cycle management of VNFs.

# NFV Use Case

- NFV can be used to virtualize the Home Gateway. The NFV infrastructure in the cloud hosts a virtualized Home Gateway. The virtualized gateway provides private IP addresses to the devices in the home. The virtualized gateway also connects to network services such as VoIP and IPTV.

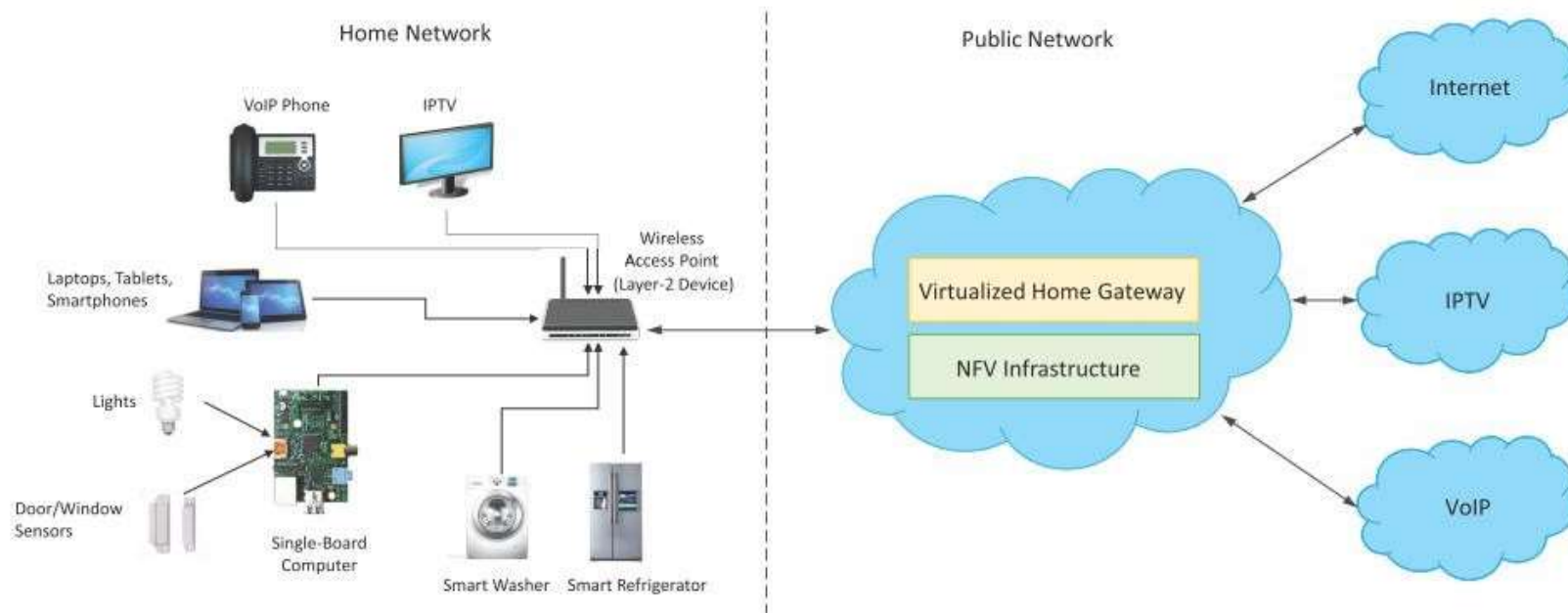



Thank you