



Static and Dynamic Balancing

Introduction

Many machines use large rotating parts – particularly vehicles. These rotating parts can create a problem. If they are not well balanced, the imbalanced centrifugal forces will create vibrations as the part rotates. This may be acceptable at low rotational velocities but can be harmful or even destructive at high velocities. Even relatively slow-moving vehicle tires need careful balancing or they will cause dangerous vibrations throughout the vehicle suspension and uneven tire wear. High speed rotating parts in jet engines must have perfectly balanced centrifugal forces, or the engine can literally shake itself to pieces resulting in an immediate and catastrophic engine explosion.

In this experiment the student should be familiar with the following concepts:

- Angular motion.
- Centrifugal force.
- Basic vector diagram construction.
- Basic trigonometry.

Objectives

This experiment aims to:

- 1- Illustrate the difference between static and dynamic balancing and the advantages of each type.
- 2- Balance a shaft by calculation or by using a graphical technique, and then to assess the accuracy of the results by setting up and running a motor driven shaft.
- 3- Show that if a shaft is dynamically balanced it is automatically in static balance, but the reverse is not necessarily true.

Theory

A shaft with masses mounted on it can be both statically and dynamically balanced. If it is statically balanced, it will stay in any angular position without rotating. If it is dynamically balanced, it can be rotated at any speed without vibration. It will be shown that if a shaft is dynamically balanced it is automatically in static balance, but the reverse is not necessarily true.

Static balancing

Figure (1) shows a simple situation where two masses are mounted on a shaft. If the shaft is to be statically balanced, the moment due to weight of mass (1) tending to rotate the shaft clockwise must equal that of mass (2) trying to turn the shaft in the opposite direction. Hence for static balance,



$$W_1 r_1 = W_2 r_2 \text{ ----- (1)}$$

The same principle holds if there are more than two masses mounted on the shaft, as shown in figure (2).

For static balance,

$$W_1 r_1 \cos(\alpha_1) = W_2 r_2 \cos(\alpha_2) + W_3 r_3 \cos(\alpha_3) \text{ ----- (2)}$$

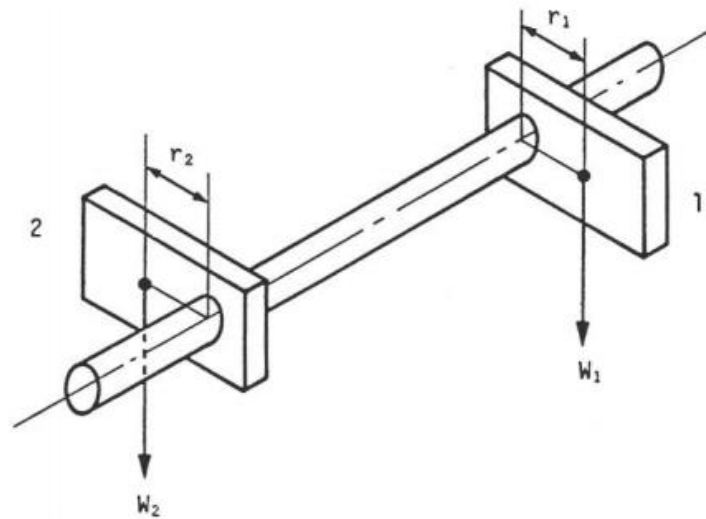

Figure 1: Simple two mass system

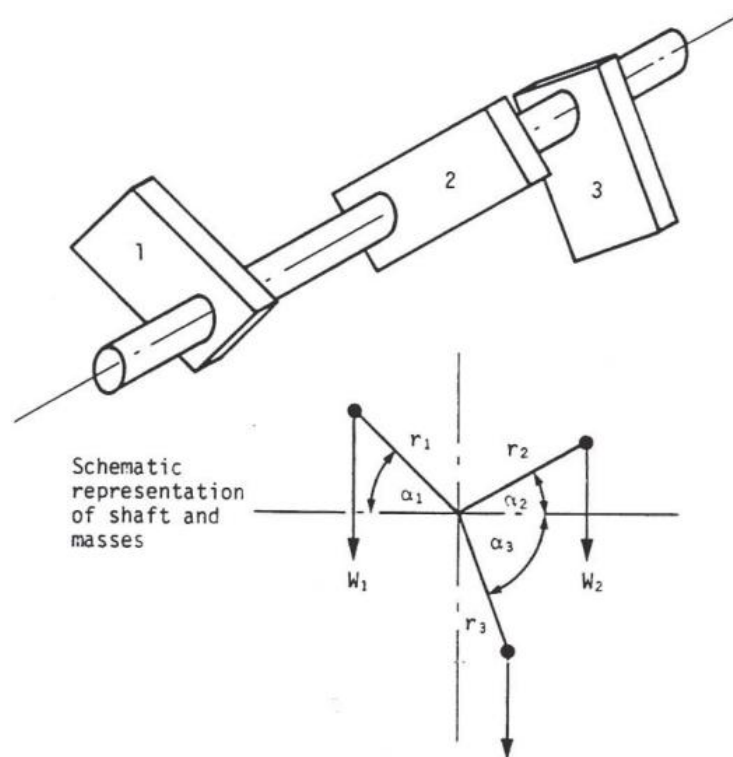

Figure 2: Three mass system

In general, values of W , r and a have to be chosen such that the shaft is in balance. However, in this experiment the product Wr can be measured directly for each mass and only the angular positions have to be determined for static balance.

If the angular positions of two of the masses are fixed, the position of the third can be found either by trigonometry or by drawing. The latter technique uses the idea that moments can be represented by vectors as shown in figure (3). The moment vector has a length proportional to the product Wr and is drawn parallel to the direction of the weight from the center of rotation.

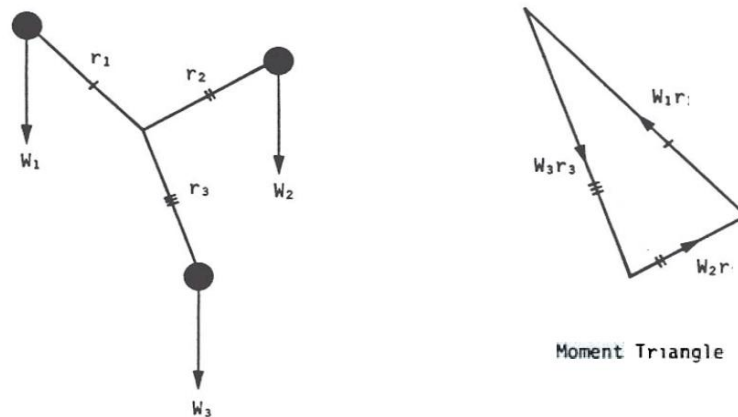

Figure 3: Moment triangle for static balance of three mass system

For static balance the triangle of moment must close and the direction of the unknown moment is chosen accordingly. If there are more than three masses, the moment figure is a closed polygon as shown in figure (4). The order in which the vectors are drawn does not matter, as indicated by the two examples on the figures.

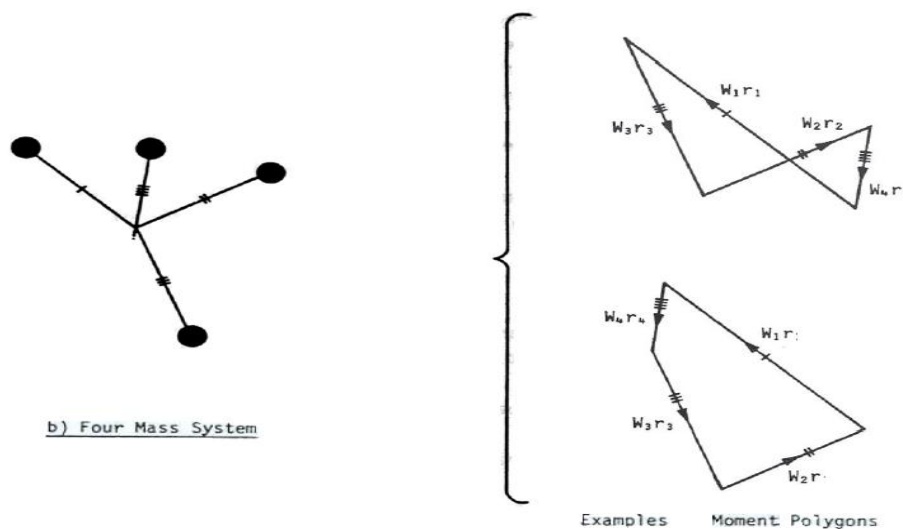

Figure 4: Moment polygon for static balance of four mass system

If on drawing the closing vector, its direction is opposite to the assumed position of that mass, the position of the mass must be reversed for balance. For example, mass (4) shown in figure (4) must be placed in the position shown dotted to agree with the direction of vector W_4r_4 .

Dynamic balancing

The masses are subjected to centrifugal forces when the shaft is rotating. Two conditions must be satisfied if the shaft is not to vibrate as it rotates:

- 1- There must be no out of balance centrifugal force trying to deflect the shaft.
- 2- There must be no out of balance moment or couple trying to twist the shaft.

If these conditions are not fulfilled, the shaft is not dynamically balanced.

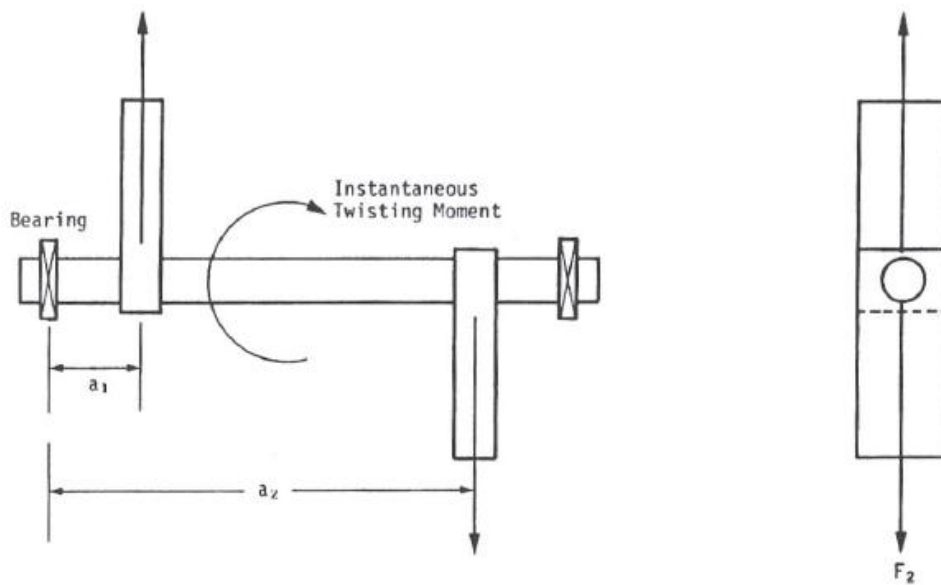

Figure 5: Dynamic out of balance for two mass system

Applying condition (a) to the shaft shown in figure (5) gives:

$$F_1 = F_2 \text{ ----- (3)}$$

The centrifugal force is $mr\omega^2$ or $\frac{W}{g}r\omega^2$, equation (3) can be written as follows:

$$\frac{W_1}{g}r_1\omega^2 = \frac{W_2}{g}r_2\omega^2 \text{ ----- (4)}$$

The angular speed of rotation is the same for each mass so that for dynamic balance:

$$W_1r_1 = W_2r_2 \text{ ----- (5)}$$

This is the same result obtained in equation (1) for the static balance of the shaft. Thus if a shaft is dynamically balanced it will also be statically balanced.



The second condition is satisfied by taking moments about some convenient datum such as one of the bearings.

Thus,
$$a_1 F_1 = a_2 F_2 \text{ --- (6)}$$

But from equation (3), $F_1 = F_2$, so that $a_1 = a_2$. Thus in this simple case, dynamic balance can only be achieved if the two masses are mounted at the same point along the shaft.

Since the reference point is immaterial, it is usually convenient to take moments about one of the masses so that the effect of that mass is deleted from the moment equation.

Taking moments about mass 1 produces the result: $F_2 (a_2 - a_1) = 0$, since the centrifugal force cannot be zero, a_1 must equal a_2 as proved above.

Unlike static balancing where the location of the masses along the shaft is not important, the dynamic twisting moments on the shaft have to be eliminated by placing the masses in carefully calculated positions. If a shaft is statically balanced it does not follow that it is also dynamically balanced.

Consider the case shown in figure (6). Mass 3 is positioned vertically for convenience. Condition (b) for dynamic balance can be expressed mathematically by equating moments for centrifugal forces in both horizontal and vertical planes. In order to simplify the equations, it is convenient to take moments about mass 1 so that moments due to forces on this mass are eliminated.

Horizontal:
$$a_2 F_2 \cos (\alpha_2) = 0 \text{ --- (7)}$$

Vertical:
$$a_2 F_2 \sin (\alpha_2) = a_3 F_3 \text{ --- (8)}$$

The conditions which satisfy equation (7) are that either $a_2 = 0$ or $\alpha_2 = 90$ or 270 . Substituting these into equation (8) gives the following conditions:

- i) $a_2 = 0$: For this condition a_3 must also be zero. Thus for arbitrary values of α_2 and α_3 , all three masses must be located at the same point along the shaft.
- ii) $\alpha_2 = 90$ or 270 : For these conditions it is necessary to write down further equations to obtain solutions.

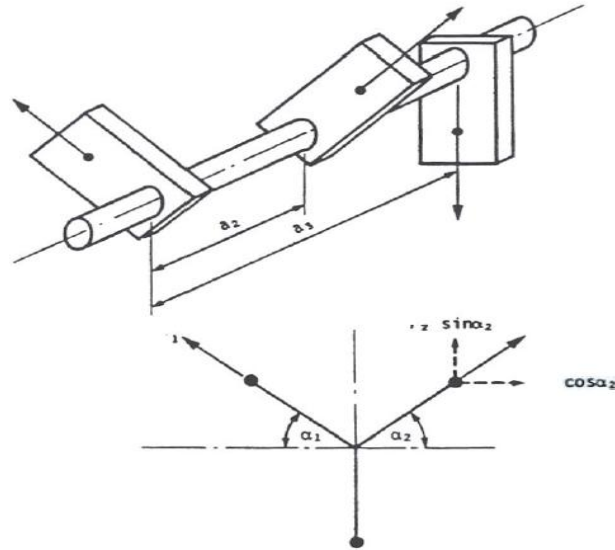

Figure 6: General case for three mass system

Applying condition (a) for dynamic balance:

Horizontal: $F_1 \cos (\alpha_1) = F_2 \cos (\alpha_2) \text{ ----- (9)}$

Vertical: $F_3 = F_1 \sin(\alpha_1) + F_2 \sin (\alpha_2) \text{ ----- (10)}$

If $\alpha_2 = 90$, equation (9) gives $\alpha_1 = 90$ or 270 . Assuming that $\alpha_1 = 90$, equation (10) reduces to: $F_3 = F_1 + F_2$.

Also, equation (8) reduces to: $a_2 F_2 = a_3 F_3$.

Combining these two equations and solving for F_1 gives:

$$F_1 = F_3 \left(\frac{-a_3}{a_2} \right) \text{ ----- (11)}$$

Now, if a_3 is greater than a_2 (as indicated in figure (6)) it follows that F_1 must be negative, and α_1 must be 270 and not 90 as assumed above. The resulting configuration for dynamic balance is shown in figure (7).

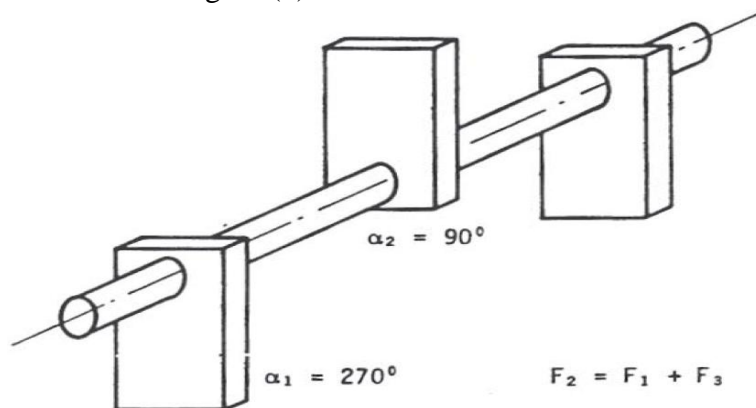

Figure 7: Actual solution for axially spaced 3 mass system



Thus, if the masses are distributed along the shaft, the following conditions must be satisfied for dynamic balance:

- a) Central mass at 180 to other two masses.
- b) Masses chosen such that,

$$F_2 = F_1 + F_3 \text{ ----- (12)}$$

- c) Masses distributed along the shaft such that,

$$a_2 F_2 = a_3 F_3 \text{ ----- (13)}$$

If there are more than three individual masses, there are no special restrictions which apply to the angular and shaft-wise distributions of the masses and the general conditions for dynamic balance have to be applied to obtain solutions.

The angular positions of the masses can be determined by applying conditions for either static balance or for condition (b) for dynamic balance. The distribution of the masses along the shaft is then found by applying condition (a) for dynamic balance. This can be done either by calculation, or by a drawing method similar to that described in static balancing section.

Calculation technique

The twisting moments are resolved into components tending to twist the shaft in the horizontal planes. The net moment in each plane must be zero if the shaft is to be dynamically balanced. As previously noted, the equations are simplified considerably by taking moments about the first mass. Referring to figure (8) the appropriate equations for a four mass system are:

Horizontal moments about mass 1:

$$-a_2 F_2 \cos(\alpha_2) + a_3 F_3 \cos(\alpha_3) + a_4 F_4 \cos(\alpha_4) = 0 \text{ ----- (14)}$$

Vertical moments about mass 1:

$$a_2 F_2 \sin(\alpha_2) + a_3 F_3 \sin(\alpha_3) - a_4 F_4 \sin(\alpha_4) = 0 \text{ ----- (15)}$$

Note that F_2 , F_3 and F_4 are proportional to $W_2 r_2$, $W_3 r_3$ $W_4 r_4$. In this experiment, the values of $W r$ are known for the masses so these values can be used in place of those for F in equations (14) and (15). Given the angular positions of two of the masses, the angular positions of the other two can be found by the methods given in static and dynamic section. If the shaft-wise locations of two of the masses are also known, the locations of the other two can be found by substituting the known values into the simultaneous equations (14) and (15).

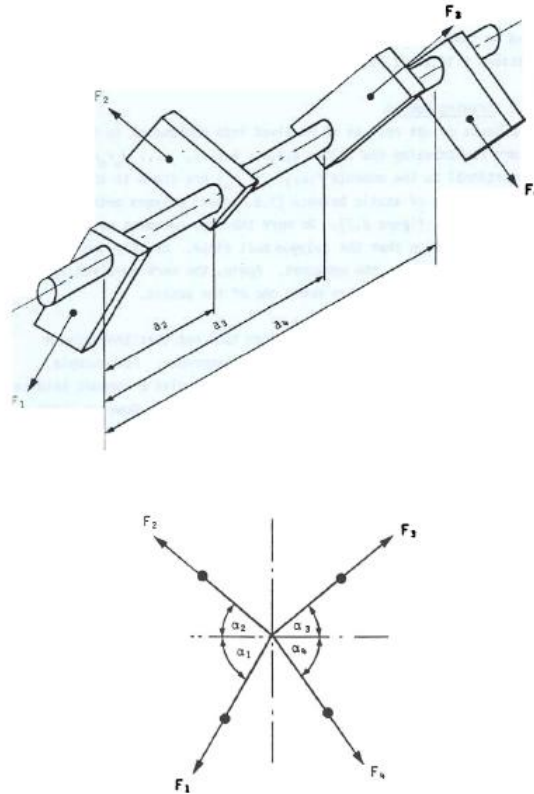

Figure 8: General case for four mass system

Drawing technique

The moments do not need to be resolved into components in this method. Vectors representing the values $W_1r_1a_1$, $W_2r_2a_2 \dots W_n r_n a_n$ (proportional to the moments $F_1a_1 \dots F_n a_n$) are drawn in the same way as for the case of static balance (i.e. moment polygon method- see figure (4)). No more than two unknowns may be found from the condition that the polygon must close. Usually two values of a are treated as the unknowns. Again, the work involved is reduced if moments are taken about one of the masses.

Whichever method is used; it will often turn out that the assumed order of the masses on the shaft will be incorrect. For example, the configuration shown in figure (8) may only give a dynamic balance if the order of the masses on the shaft is altered. However, both methods automatically account for this since the resulting values of a will indicate in which order the masses must be placed on the shaft. Generally, the diagrams show purely arbitrary positions for the masses.

Experimental Procedures

Part 1: Demonstration of Static Balance but Dynamic Imbalance

- 1) Remove the safety dome and shaft drive belt.
- 2) Remove the discs from the four rectangular blocks using the smaller hexagon key.
- 3) Set up two of the blocks as shown in figure (9-a) with a relative angular displacement of 180 and shaft-wise displacement of 120mm. Use the slider to set



and read off the positions of the blocks. The larger hexagon key fits the screws which clamp the rectangular blocks onto the shaft.

- 4) Observe that the shaft will remain in any angular position and is therefore statically balanced.
- 5) Connect the apparatus to an electricity socket. Make sure that the slider adjacent to the linear scale is clear of the blocks, then replace the shaft drive-belt and the safety dome.
- 6) Briefly run the motor. Note the severe imbalance of the shaft.

Part 2: Simple Dynamic Balance using Four Masses

- 1) Remove the safety dome and set up the four rectangular blocks as shown in figure (9-b).
- 2) Test the shaft for static balance.
- 3) Replace the drive-belt and the safety dome. Run the motor and observe the lack of vibrations, showing that the shaft is dynamically balanced.

Part 3: Experimental determination of W_r values

- 1) Remove the safety dome and remove the shaft drive belt.
- 2) Unclip the extension pulley and insert it in the pulley end of the motor driven shaft.
- 3) Move the apparatus to the edge of the table or bench.
- 4) Loop two or three turns of the weight bucket cord around the extension pulley. Ensure that there are no obstructions to the movement of the weight buckets.
- 5) Insert the eccentric disc with the small hole into one of the rectangular blocks. Clamp the block to the shaft at about half way along (90 mm) using the slider to hold it whilev such that the protractor scale reading is 0. Call this block (1).
- 6) Gradually add the circular weights to one of the weight buckets until the block has moved through 90. Whilst adding the weights, occasionally tap the shaft mountings to overcome bearing stiction.
- 7) Record the number of weights required to raise the block through 90. This is proportional to the out of balance moment of the block (W_r).
- 8) Fit an eccentric disc to each block and repeat the above procedure for each block in turn.
- 9) Enter the results in a table 1.
- 10) Remove the extension shaft and replace it in its mounting clip.

Table 1: Experimental determination of W_r

Block #	1	2	3	4
W_r [N.m]				

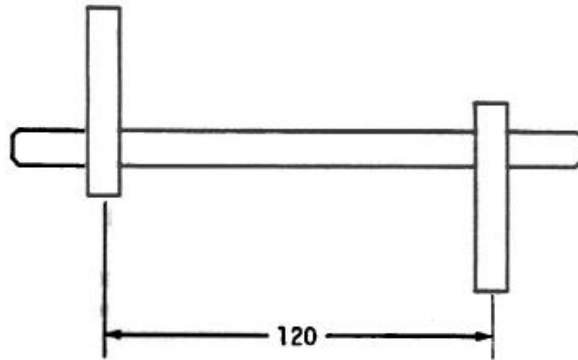

a) Static Balance for 2 Mass System

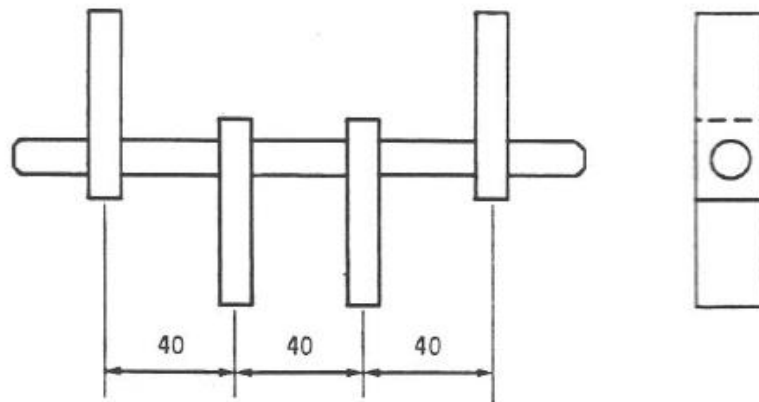

b) Static and Dynamic Balance for 4 Mass System

Figure 9: Configurations for Simple Demonstrations (parts 1 and 2)

Part 4: Static and Dynamic Balancing of a Four Mass System

- 1) Assume the initial angles and position for blocks 1 and as shown in table (2).
- 2) Find the angular positions of blocks 3 and 4 using drawing method.
- 3) Find the horizontal positions of blocks 3 and 4 using drawing method.
- 4) Use the slider and protractor to set the blocks on the shaft according to table (2).
- 5) Move the horizontal slider out of the way such that the blocks can rotate without hitting anything.
- 6) Make sure the two locking clamps hold the assembly in place
- 7) Test for static balance.
- 8) Undo the locking clamps and turn them away from the assembly.
- 9) Replace the drive belt and the safety dome.
- 10) Press and hold the motor button and check if the shaft is dynamically balanced or not.

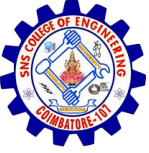

Table 2: Static and Dynamic Balancing of a Four Mass System

Block #	1	2	3	4	Block order
θ_{block} [degrees]	0	100			3124
X_{block} [mm]	20	120			

Discussion and Conclusions

Part 1: Demonstration of Static Balance but Dynamic Imbalance, answer questions 1 and 2:

- 1) Prove that this system is statically balanced?
- 2) Is this system dynamically balanced? Justify your answer.

According to part 2: Simple Dynamic Balance using Four Masses, answer question 3:

- 3) Prove theoretically that the shaft is both statically and dynamically balanced?

According to part 4: Static and Dynamic Balancing of a Four Mass System, answer question 4:

- 4) Find the unknown angles and distances using graphical method.