



SNS COLLEGE OF ENGINEERING

Kurumbapalayam (Po), Coimbatore – 641 107

An Autonomous Institution

Accredited by NBA – AICTE and Accredited by NAAC – UGC with 'A' Grade
Approved by AICTE, New Delhi & Affiliated to Anna University, Chennai

DEPARTMENT OF ELECTRICAL AND ELECTRONICS ENGINEERING

COURSE NAME : 23EET101 BASIC ELECTRICAL AND ELECTRONICS ENGINEERING

1. CONSTRUCTION OF DC MACHINE

B.Sajitha
CFC Co-Ordinator
SNS Institutions



DC GENERATOR OR DC MACHINE

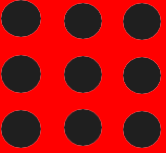

- Why do we need Generators?
- What is the difference between AC & DC Source?

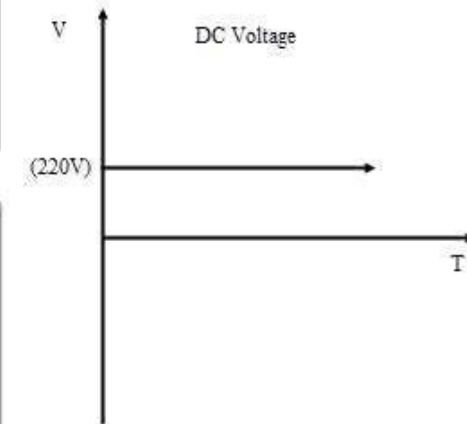
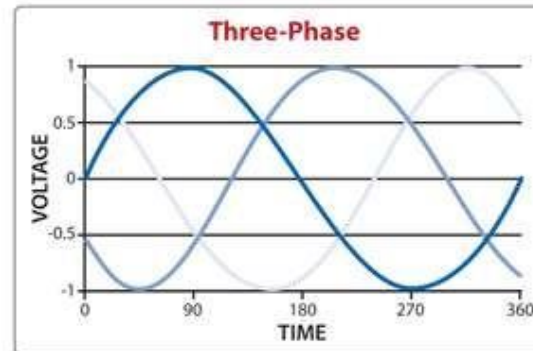
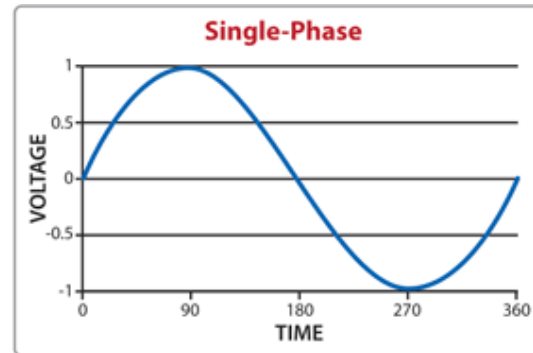



FARADAYS LAW OF ELECTROMAGNETIC INDUCTION

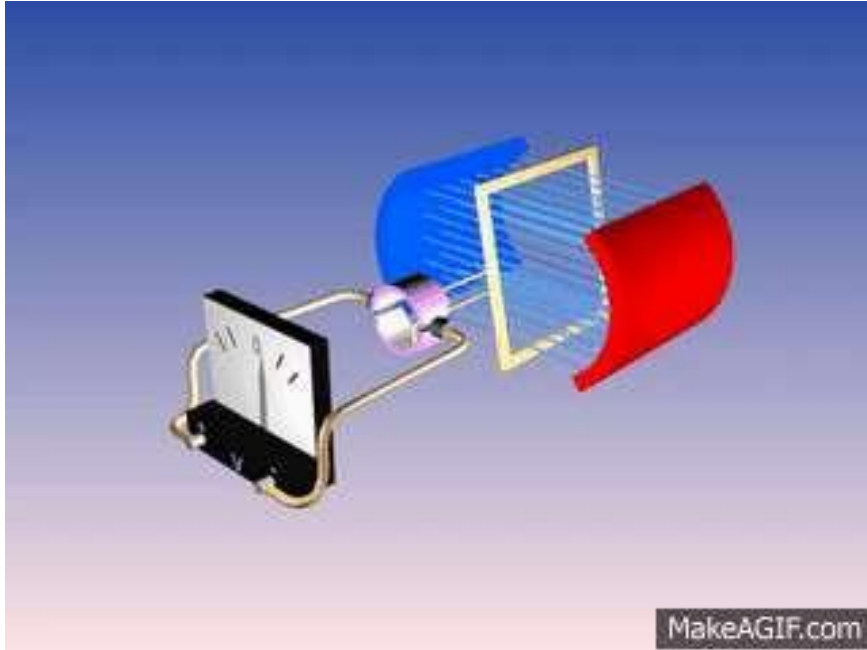
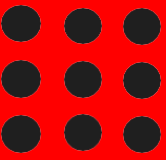

DC Generator Principle

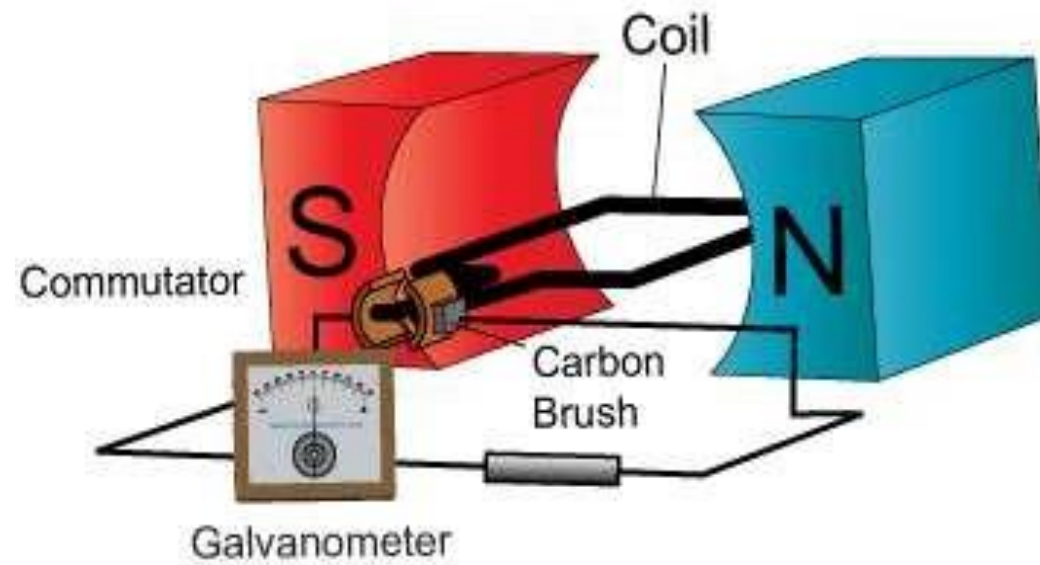



CONSTRUCTION OF DC MACHINE

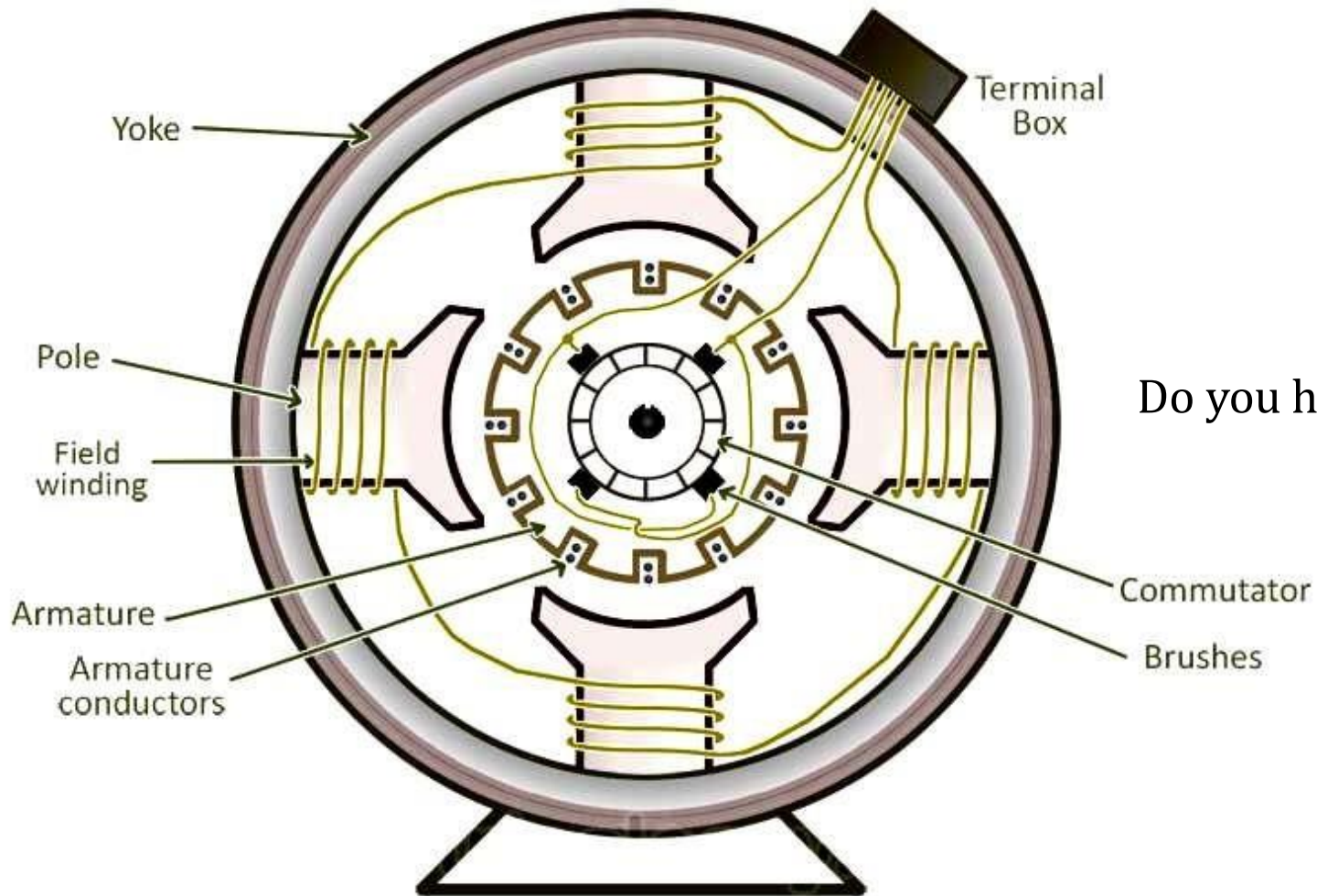
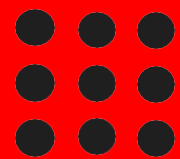

Do you have confidence to elaborate?





POLE, POLE CORE & POLE SHOES

- The pole is an electromagnet and the field winding is winding around pole.
- Whenever field winding is energized then the pole gives magnetic flux.
- The materials used for this are cast steel, cast iron otherwise pole core.
- Pole shoe in DC machine is an extensive part as well as enlarge the region of the pole.

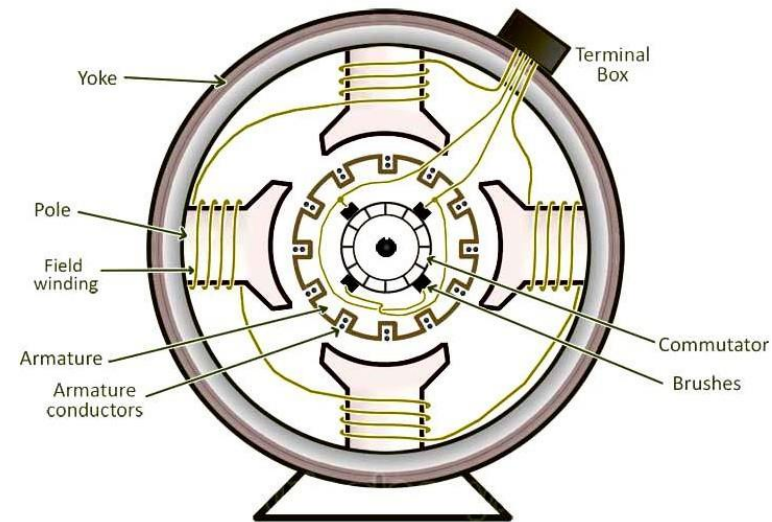
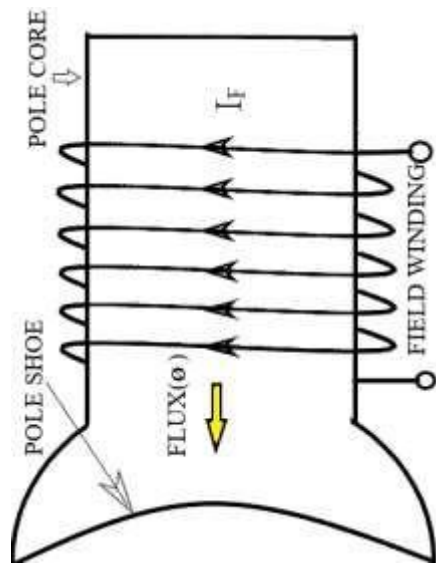



FIELD WINDINGS

- The copper windings are wound in the region of pole core & named as field coil.
- Whenever current is supplied through field winding then it electromagnetics the poles which generate required flux.

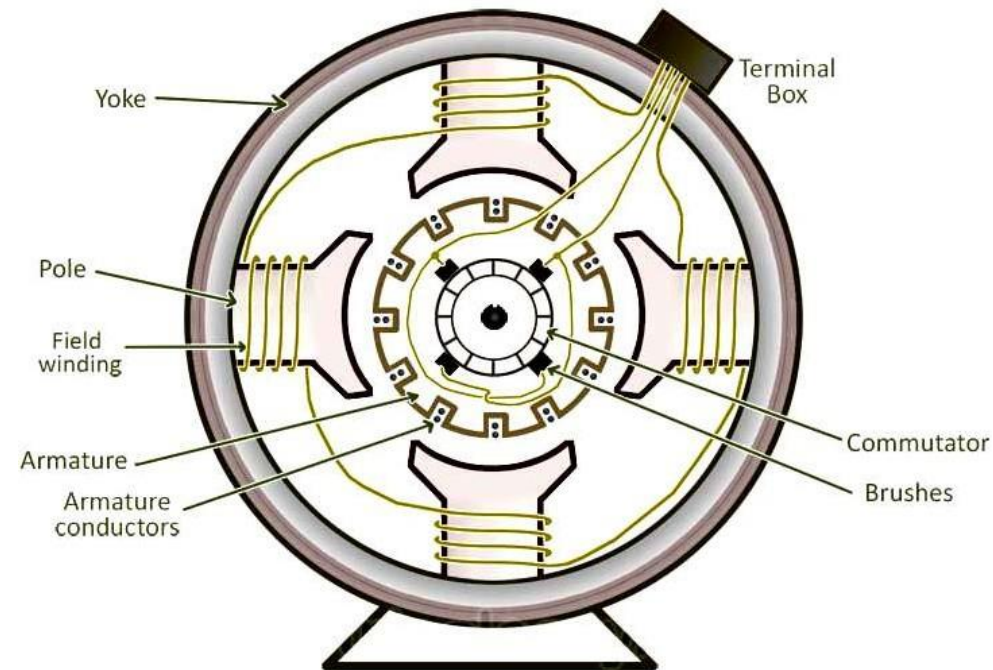



ARMATURE CORE & ARMATURE WINDING

- Armature core includes the huge number of slots within its edge.
- Armature winding is located in these slots.
- It provides the low-reluctance path toward the flux generated with field winding.
- The lamination is used to decrease the loss because of the eddy current.

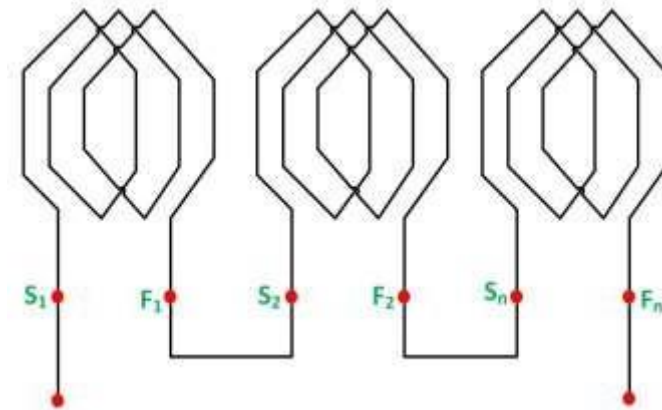
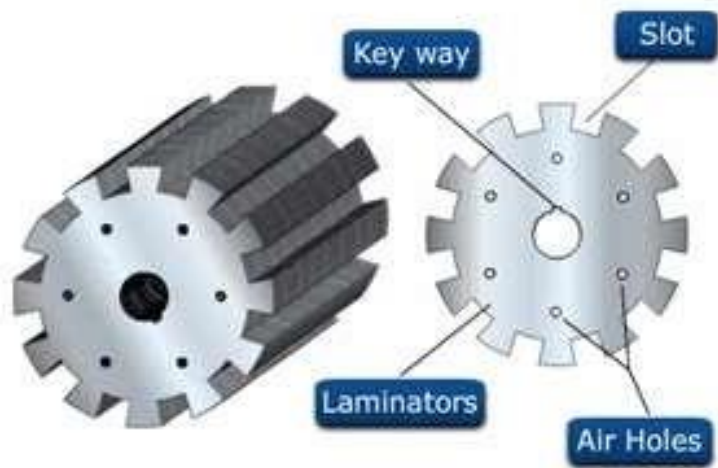



ASSESSMENT 1

1. The armature of DC motor is laminated to

- a) To reduce mass
- b) To reduce hysteresis loss
- c) To reduce eddy current loss
- d) To reduce inductance

2. The armature of DC generator is laminated to

- a) Reduce Hysteresis loss
- b) Insulate the Core
- c) Reduce eddy current loss
- d) Provide air cooling passage

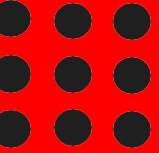



COMMUTATOR

- The main function is to collect the current from the armature conductor as well as supplies the current to the load using brushes.
- It also provides uni-directional torque for DC-motor.

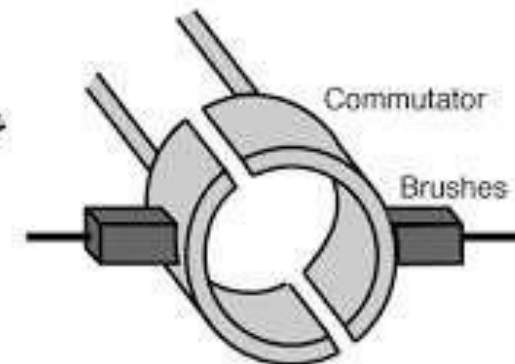
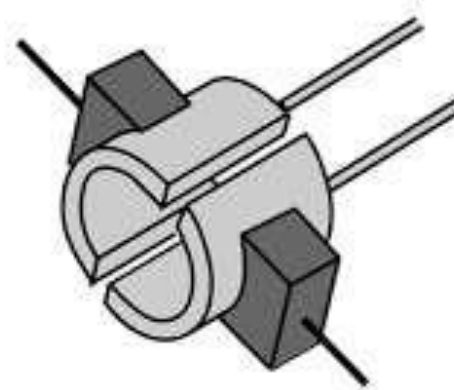



BRUSHES

- Brushes are used to collect the current from commutator and supplies it to exterior load.
- The materials used in brushes are graphite otherwise carbon which is in rectangular form.

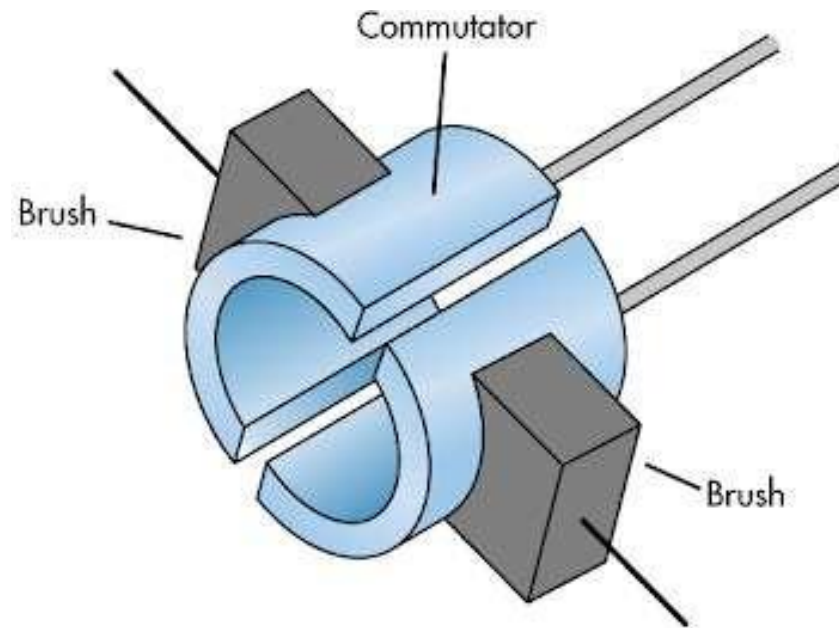



YOKE

The main function of the yoke in the machine is to offer mechanical support intended for poles and protects the entire machine from the moisture, dust, etc.

It is also to reduce the magnetic flows outside.

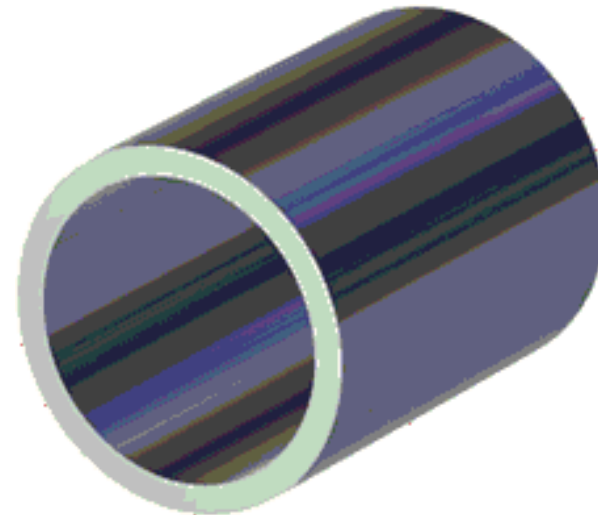



Assessment 2

1.The material for commutator Brushes is generally

- A.Mica
- B.Cast Iron
- C.Copper
- D.Carbon

2.Aluminium is selected as the material for rotating disc of energy meter because

- A.It is good conductor
- B.It is light
- C.It is indigenously available
- D.All of the above reasons





REFERENCES

1. Bhattacharya. S.K, “Basic Electrical and Electronics Engineering”, Pearson Education , (2017)
2. Muthu Subramanian R, Salivahanan S,“ Basic Electrical and Electronics Engineering”, Tata McGraw Hill Publishers, (2009)
3. V.Mittle“ Basic Electrical Engineering”, Tata McGraw Hill Publishers, (2017)
4. Nagrath. I.J, “Electronics: Analog and Digital”, Prentice Hall India Pvt. Ltd., (2013)

THANK YOU