



SNS COLLEGE OF ENGINEERING

Kurumbapalayam (Po), Coimbatore – 641 107

An Autonomous Institution

Accredited by NBA – AICTE and Accredited by NAAC – UGC with 'A' Grade

Approved by AICTE, New Delhi & Affiliated to Anna University, Chennai

DEPARTMENT OF ELECTRICAL AND ELECTRONICS ENGINEERING

**COURSE NAME : 23EET01 BASIC ELECTRICAL AND ELECTRONICS
ENGINEERING**

I YEAR /II SEMESTER COMPUTER SCIENCE & TECHNOLOGY

Unit 1 – Electrical Circuits and Measurements

Kirchhoff's Law

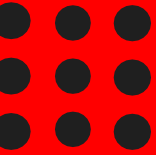



KIRCHHOFF'S LAW

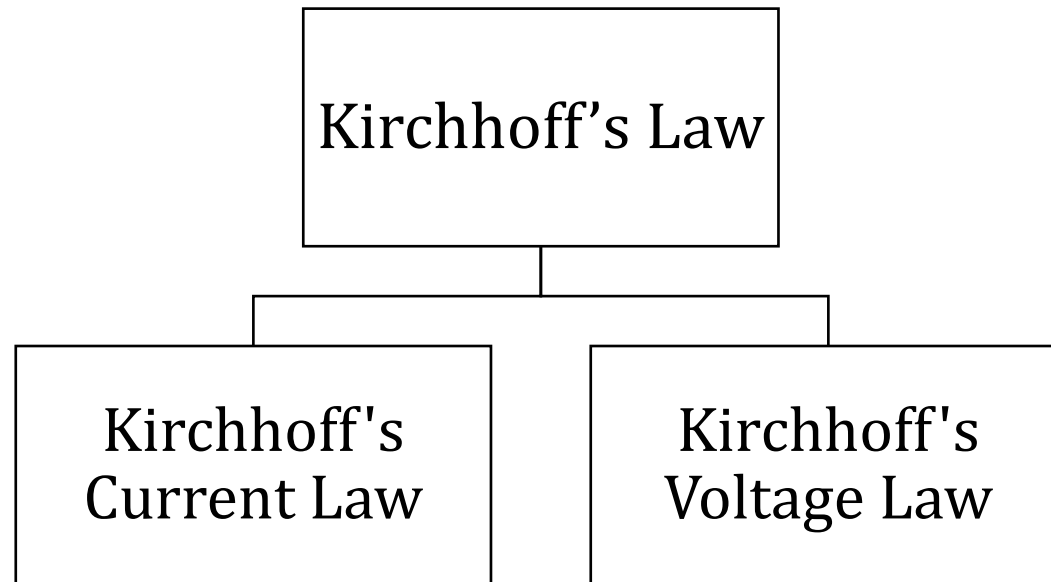

**Gustav Robert Kirchhoff
(1824-1887)**



KIRCHHOFF'S CURRENT LAW

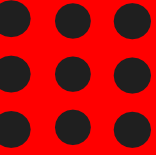

In an electrical circuit, the current flows rationally as electrical quantity. As the flow of current is considered as flow of quantity, at any point in the circuit the total current enters, is exactly equal to the total current leaves the point. The point may be considered anywhere in the circuit.

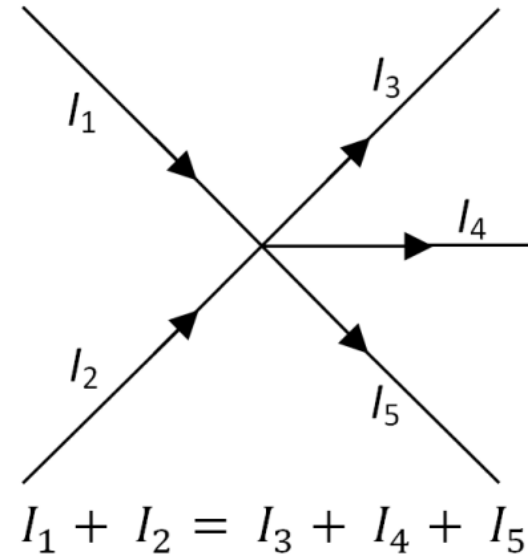



KIRCHHOFF'S VOLTAGE LAW

- Kirchoffs Voltage Law or KVL, states that “in any closed loop network, the total voltage around the loop is equal to the sum of all the voltage drops within the same loop” which is also equal to zero. In other words the algebraic sum of all voltages within the loop must be equal to zero.

The sum of all the Voltage Drops around the loop is equal to Zero

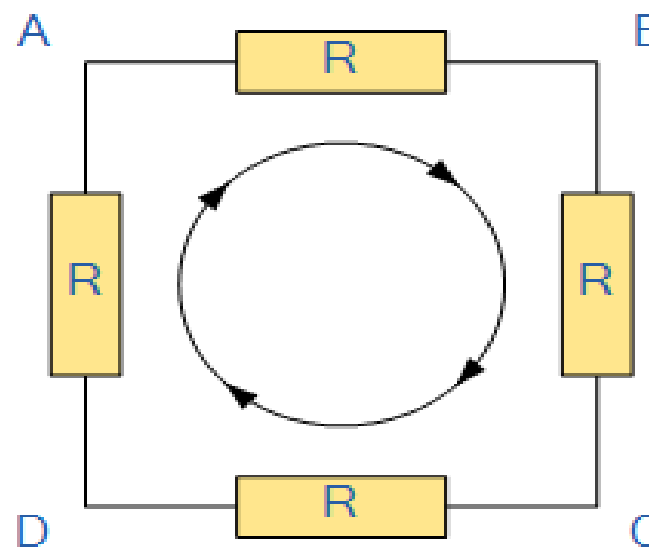

$$V_{AB} + V_{BC} + V_{CD} + V_{DA} = 0$$



VOLTAGE DIVISION RULE

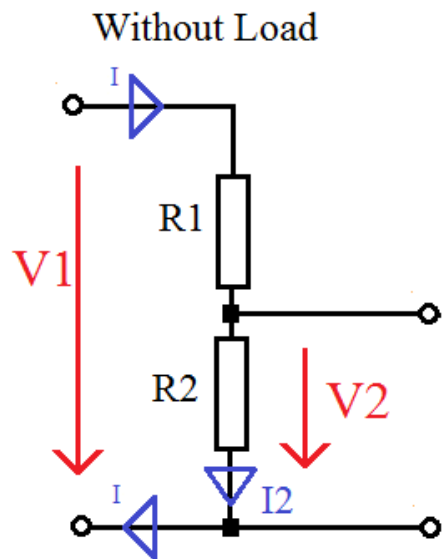

$$I = \frac{V1}{R1 + R2} = \frac{V2}{R2}$$



$$\frac{V1}{V2} = \frac{R1 + R2}{R2}$$

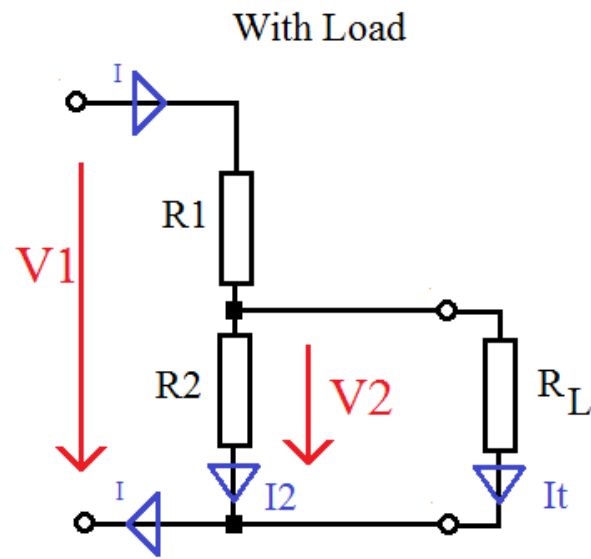

$$I = \frac{V1}{R1 + (R2 \times R_L)} = \frac{V2}{(R2 \times R_L)}$$

$$I = I2 + It$$
$$I2 = V2 / R2$$
$$It = V2 / R_L$$

$$\frac{V1}{V2} = \frac{R1 + (R2 \times R_L)}{(R2 \times R_L)}$$



CURRENT DIVISION RULE

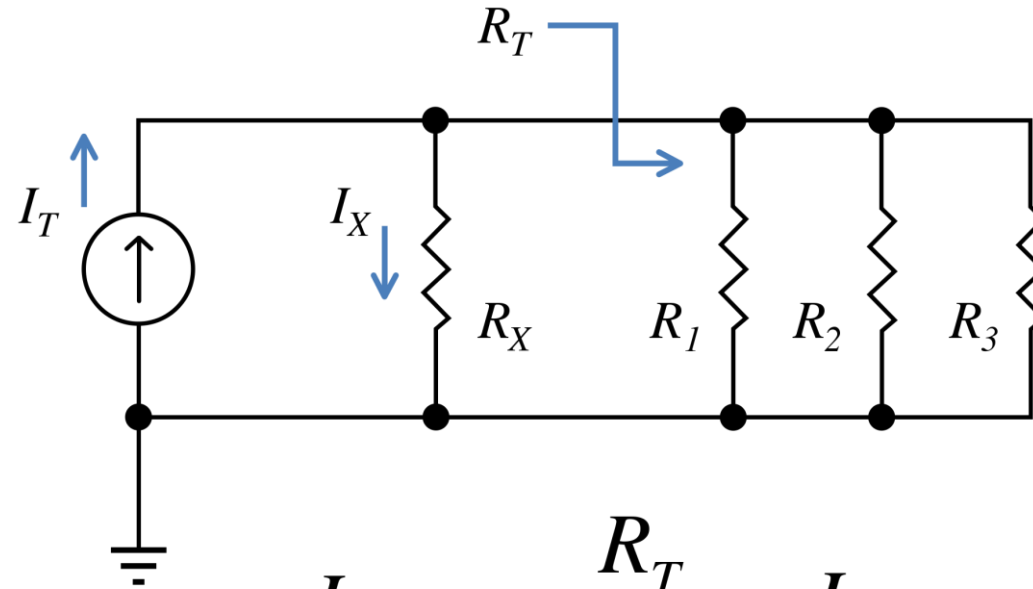

$$I_X = \frac{R_T}{R_X + R_T} I_T$$



PROCEDURE FOR APPLYING RULES

1. Assume all voltage sources and resistances are given. (If not label them V_1 , V_2 ..., R_1 , R_2 etc)
2. Label each branch with a branch current. (I_1 , I_2 , I_3 etc)
3. Apply junction rule at each node.
4. Applying the loop rule for each of the independent loops of the circuit.
5. Solve the equations by substitutions/linear manipulation.





ASSESSMENT 1

Determine the values of the current flowing through each of the resistors.

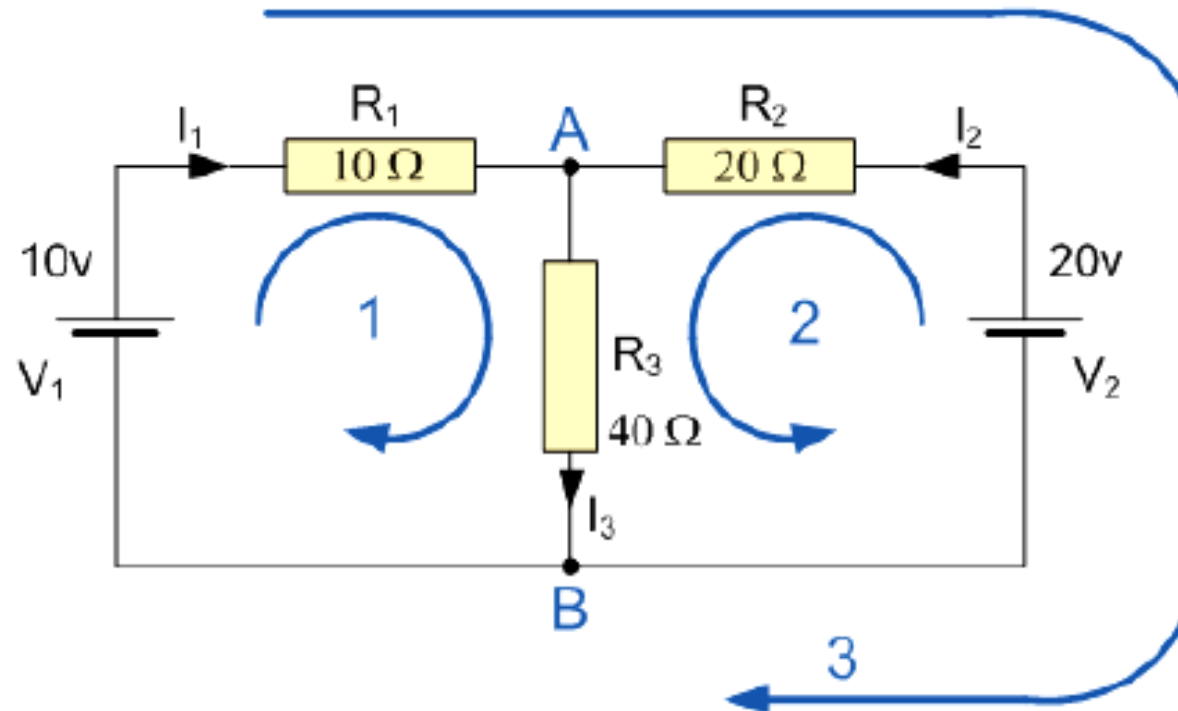



SOLUTION

The circuit has two nodes (at A and B). We have the choice of choosing only two of the three loops shown (blue). This is because only two of the loops are independent.

- Node A
- Node B
- Loop 1
- Loop 2 $I_1 + I_2 = I_3$ $I_3 = I_1 + I_2$
- $10 - I_1 R_1 - I_3 R_3 = 0$
- $20 - I_2 R_2 - I_3 R_3 = 0$

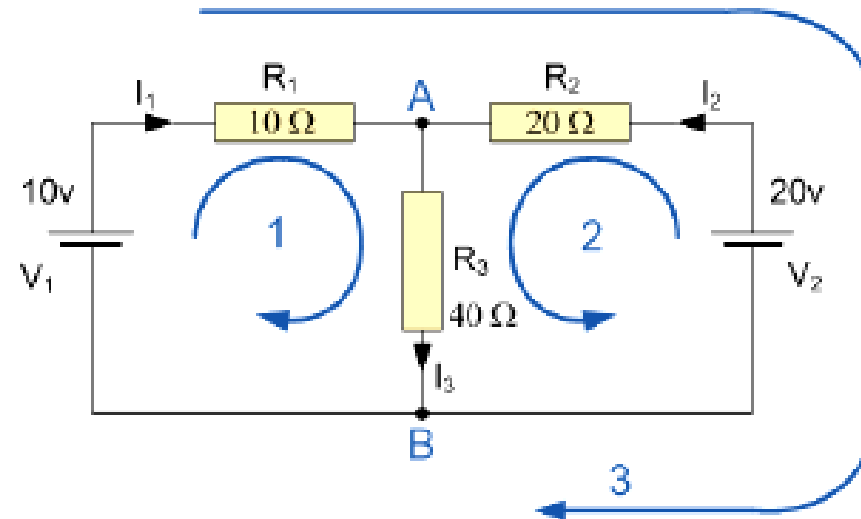



REFERENCES

1. Bhattacharya. S.K, “Basic Electrical and Electronics Engineering”, Pearson Education , (2017)
2. Muthu subramanian R, SalivahananS,“ Basic Electrical and Electronics Engineering”, Tata McGraw Hill Publishers, (2009)
3. V.Mittle“ Basic Electrical Engineering”, Tata McGraw Hill Publishers, (2017)
4. Nagrath. I.J, “Electronics: Analog and Digital”, Prentice Hall India Pvt. Ltd., (2013)
5. Black & Decker , “The complete guide to Electrical Wiring” , S.Chand & Company Ltd,(2012)

THANK YOU