



SNS COLLEGE OF ENGINEERING

Kurumbapalayam (Po), Coimbatore – 641 107

An Autonomous Institution

Accredited by NBA – AICTE and Accredited by NAAC – UGC with 'A' Grade
Approved by AICTE, New Delhi & Affiliated to Anna University, Chennai

DEPARTMENT OF COMPUTER SCIENCE AND DESIGN

COURSE NAME : 19EE01 BASIC ELECTRICAL AND ELECTRONICS ENGINEERING

I YEAR /II SEMESTER - COMPUTER SCIENCE AND DESIGN

Unit 2 – ELECTRICAL MACHINES

Topic 1 : Voltage Equation & Characteristics of DC Generator

GENERAL REPRESENTATION OF DC GENERATOR

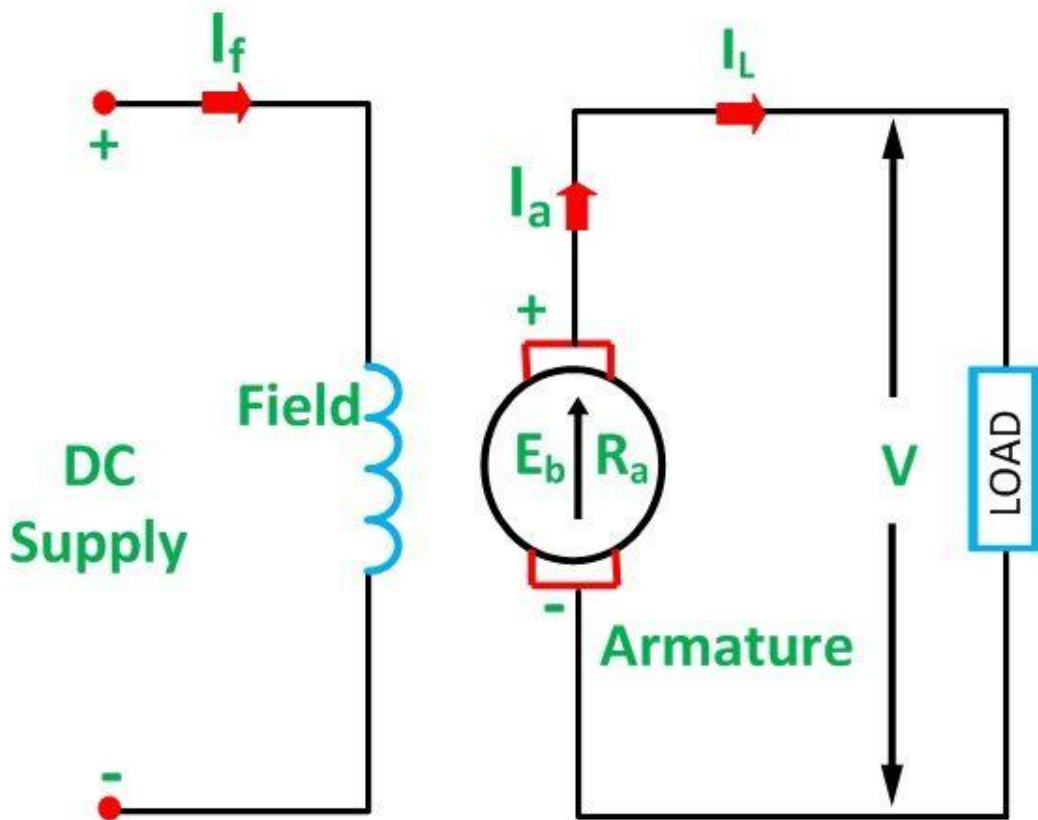

Field Winding – Electromagnet

I_f - Field current

Armature Winding – Motor shape

I_a - Armature current

I_L - Load Current

V -Voltage across the load

Circuit Globe



TYPES OF DC GENERATOR

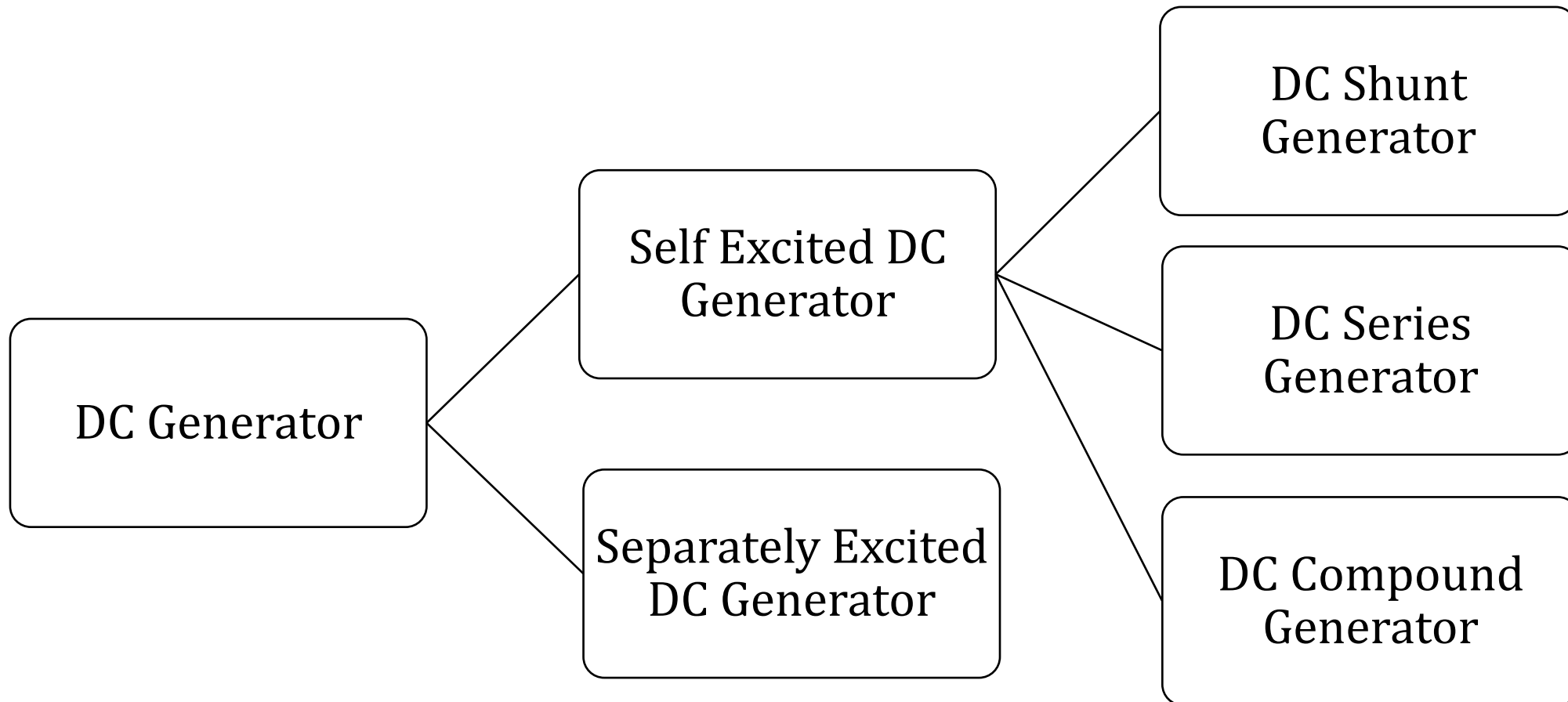

SEPERATELY EXCITED DC GENERATOR

$I_a = I_L$ where I_a is the armature current and I_L is the line current.

Terminal voltage is given as

$$V = E_g - I_a R_a \dots\dots (1)$$

If the contact brush drop is known, then the equation (1) is written as

$$V = E_g - I_a R_a - 2v_b \dots\dots (2)$$

- The power developed is given by the equation shown below

$$\text{Power developed} = E_g I_a \dots\dots\dots (3)$$

$$\text{Power output} = V I_L = V I_a \dots\dots\dots (4)$$

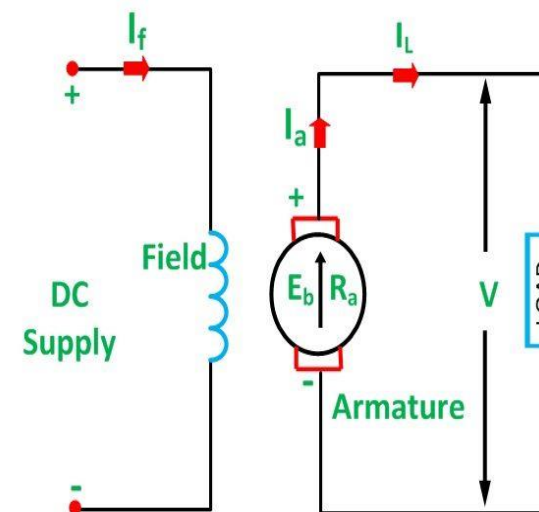

Circuit Globe

SELF EXCITED DC GENERATOR

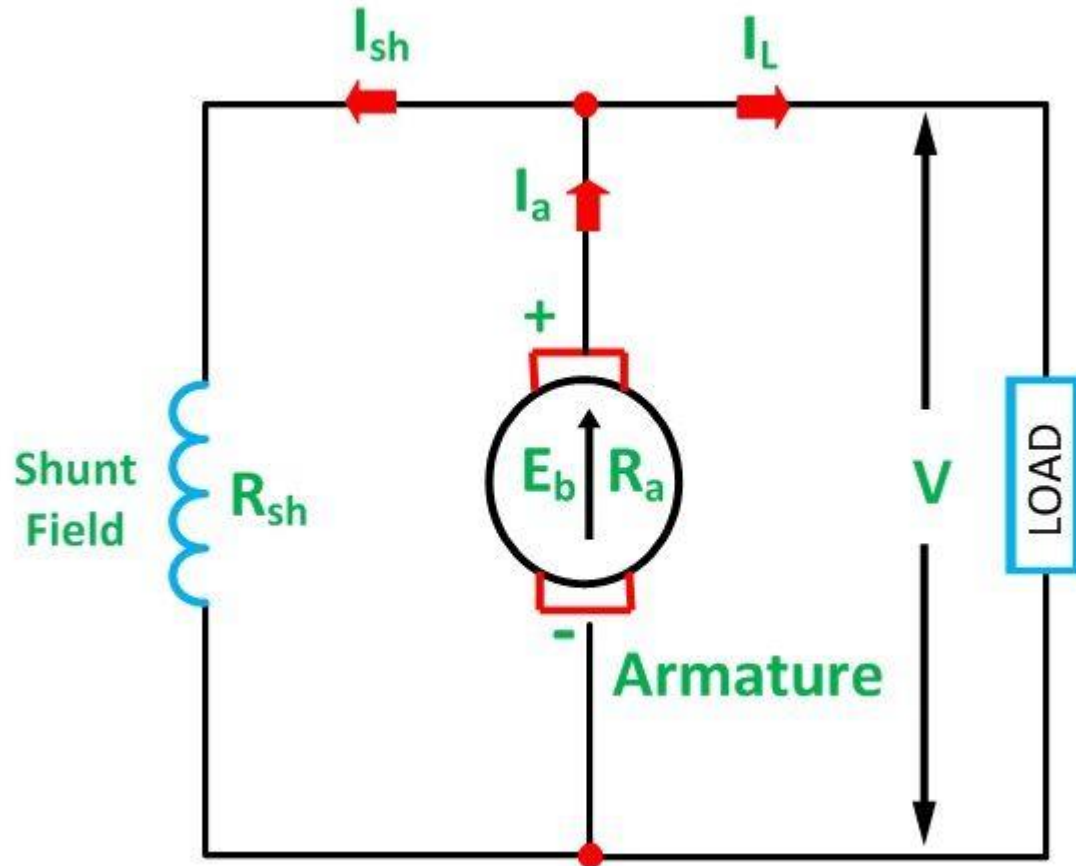

Field winding is self excited

Circuit Globe



ASSESSMENT 1

1. Classify the types of DC Generators



SHUNT GENERATOR

$$I_{sh} = \frac{V}{R_{sh}}$$

$$I_a = I_L + I_{sh}$$

$$V = E_g - I_a R_a$$

$$V = E_g - I_a R_a - 2v_b$$

$$\text{Power developed} = E_g I_a$$

$$\text{Power output} = V I_L$$

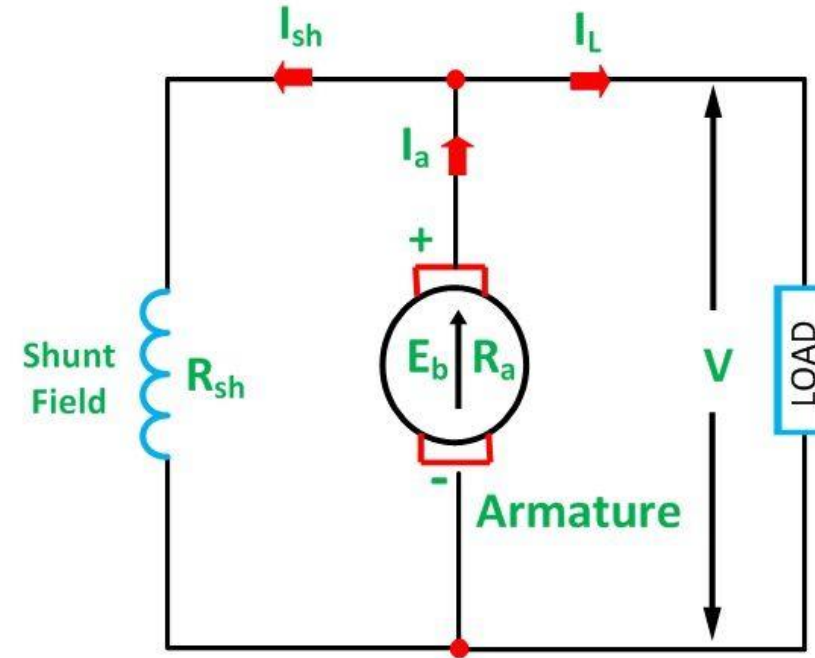

Circuit Globe

SERIES GENERATOR

$$I_{se} = I_L = I_a$$

$$V = E_g - I_a R_a - I_{se} R_{se}$$

$$V = E_g - I_a (R_a + R_{se})$$

$$V = E_g - I_a (R_a + R_{se}) - 2V_b$$

$$\text{Power developed} = E_g I_a$$

$$\text{Power output} = V I_L = V I_a$$

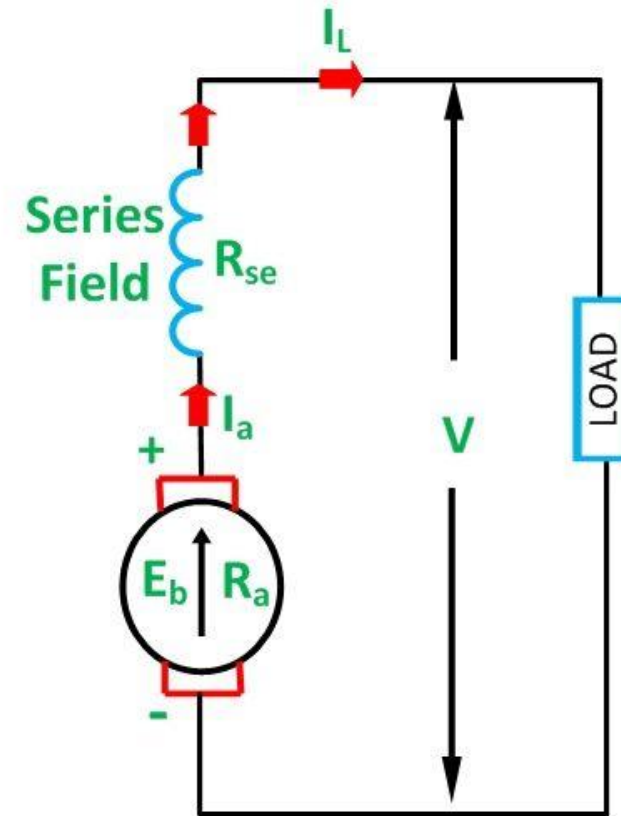

Circuit Globe

COMPOUND GENERATOR

Long Shunt Compound Wound Generator

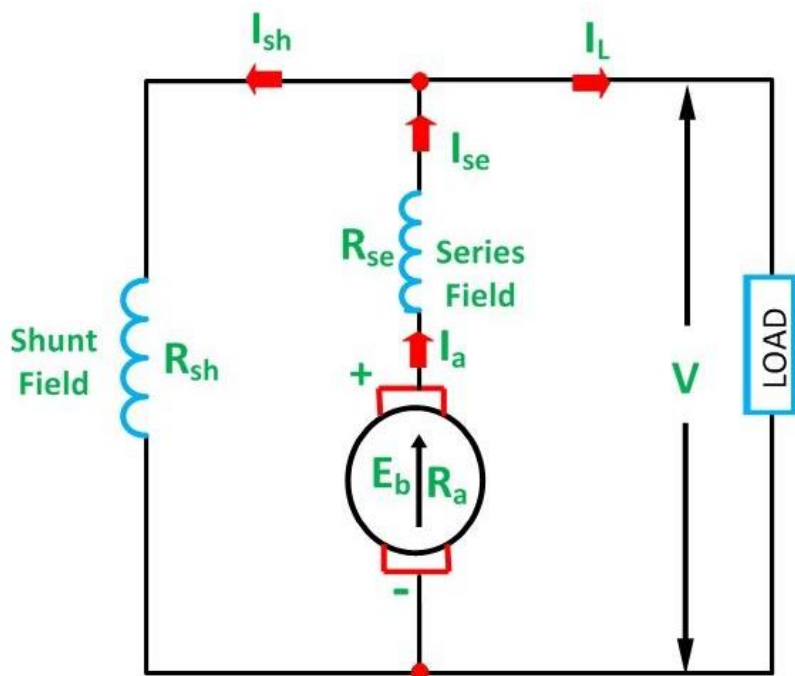

Short Shunt Compound Wound Generator

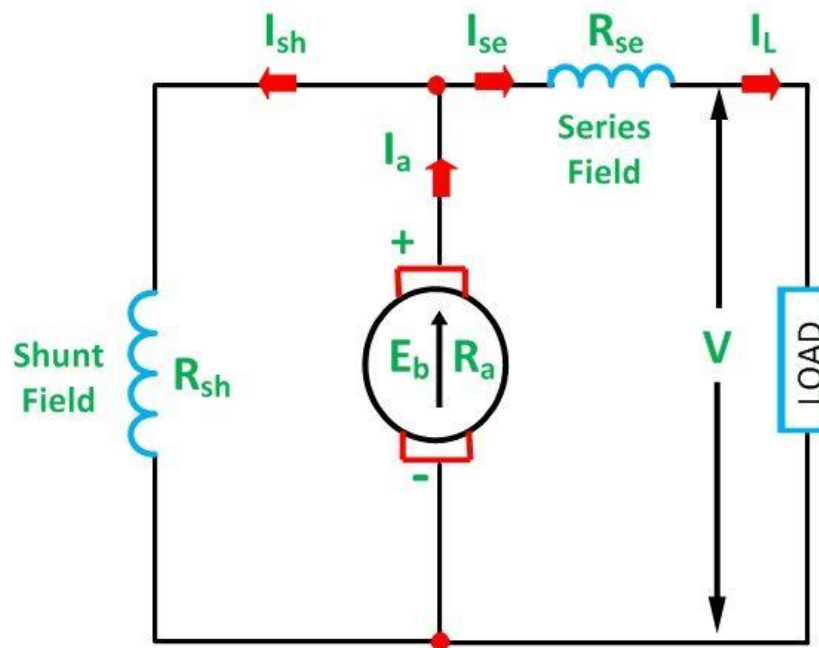

Characteristics of DC Generator

- Open Circuit Characteristics
- Load Characteristics

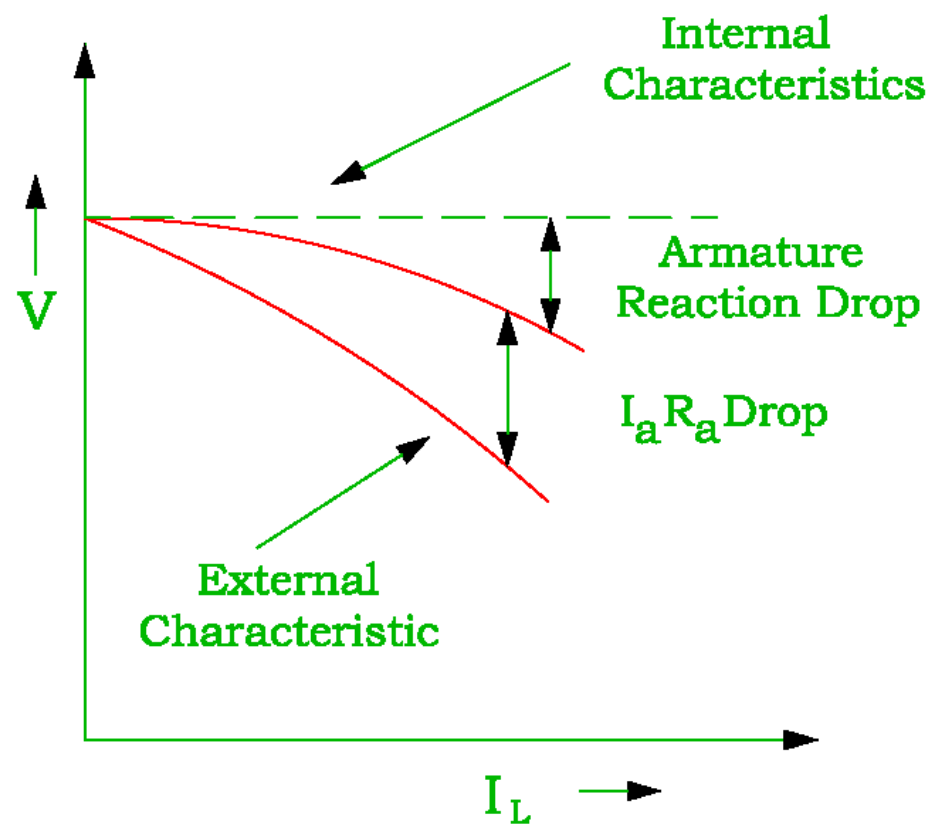
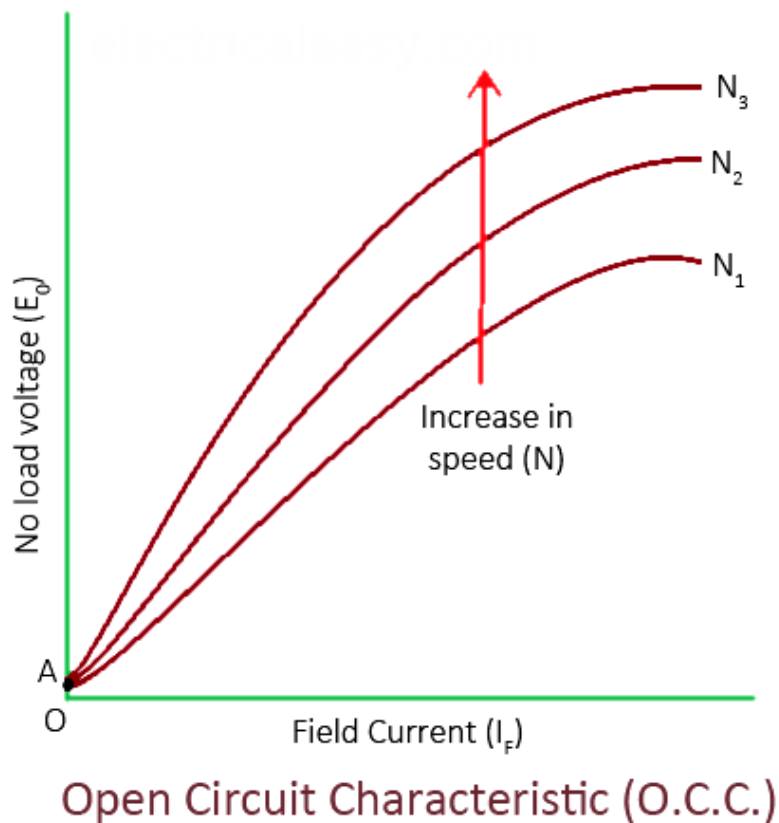



Assessment 2

1. Write the Voltage equation of DC Series Generator.





REFERENCES

1. Bhattacharya. S.K, “Basic Electrical and Electronics Engineering”, Pearson Education , (2017)
2. Muthu Subramanian R, Salivahanan S,“ Basic Electrical and Electronics Engineering”, Tata McGraw Hill Publishers, (2009)
3. V.Mittle“ Basic Electrical Engineering”, Tata McGraw Hill Publishers, (2017)
4. Nagrath. I.J, “Electronics: Analog and Digital”, Prentice Hall India Pvt. Ltd., (2013)

THANK YOU